

TM 11-6625-678-15

DEPARTMENT OF THE ARMY TECHNICAL MANUAL

ORGANIZATIONAL, DS, GS, AND DEPOT
MAINTENANCE MANUAL

ANALYZER-CHARGER, BATTERY AN/ASM-137

This copy is a reprint which includes current
pages from Changes 1 and 2.

HEADQUARTERS, DEPARTMENT OF THE ARMY
SEPTEMBER 1967

WARNING

DANGEROUS VOLTAGES AND CURRENTS EXIST IN THIS EQUIPMENT

Be careful when working on the input power 117-volt ac line or the output high current connections. Serious injury or death may result from contact with these terminals.

DON'T TAKE CHANCES!

TECHNICAL MANUAL }
 NO. 11-6625-678-15 }

HEADQUARTERS
 DEPARTMENT OF THE ARMY
 WASHINGTON, DC, 18 September 1967

**ORGANIZATIONAL, DIRECT SUPPORT, GENERAL SUPPORT, AND
 DEPOT MAINTENANCE MANUAL
 INCLUDING REPAIR PARTS AND SPECIAL TOOLS LIST
 ANALYZER CHARGER, BATTERY AN/ASM-137**

		Paragraph	Page
CHAPTER	1. INTRODUCTION		
Section	I. General		
	Scope	1-1	1-1
	Indexes of publications	1-2	1-1
	Forms and records	1-3	1-1
	Reporting of errors	1-3.1	1-1
	Reporting equipment improvement recommendations (EIR)	1-3.2	1-1
	II. Description and data		
	Purpose and use	1-4	1-1
	Technical characteristics.	1-5	1-1
	Description	1-6	1-2
	Items comprising an operable equipment	1-7	1-2
CHAPTER	2. INSTALLATION AND OPERATING INSTRUCTIONS		
Section	I. Service upon receipt of equipment		
	Unpacking	2-1	2-1
	Checking unpacked equipment	2-2	2-1
	Installation of equipment	2-3	2-1
	II. Operation		
	Controls and indicators	2-4	2-3
	Starting procedure	2-5	2-4
	Operating procedure.	2-6	2-5
	Stopping procedure	2-7	2-6
CHAPTER	3. OPERATOR AND ORGANIZATIONAL MAINTENANCE		
	Scope of maintenance	3-1	3-1
	Preventive maintenance	3-2	3-1
	Preventive maintenance checks and services periods.	3-3	3-1
	Operator's daily preventive maintenance checks and services chart	3-4	3-1
	Operator's weekly preventive maintenance checks and services chart	3-5	3-2
	Organizational monthly preventive maintenance checks and services chart	3-6	3-2
	Organizational quarterly preventive maintenance checks and services chart	3-7	3-3
	Cleaning	3-8	3-3
	Touchup painting instructions	3-9	3-3
	General troubleshooting information	3-10	3-3
	Organizational troubleshooting chart.	3-11	3-3
	Replacement of indicator lamps and fuse	3-12	3-4
	Block diagram	4-1	4-1
	Input circuit	4-2	4-1
	Passing-regulator circuit	4-3	4-2
	Timer-programmer circuit	4-4	4-5
	Monitoring circuit	4-5	4-6
	5. TROUBLESHOOTING		
	General instructions.	5-1	5-1
	Organization of troubleshooting procedures.	5-2	5-1

*This manual supersedes TM 11-6625-678-15, 24 March 1966.

		Paragraph	Page
	Test equipment required	5-3	5-3
	Localizing trouble	5-4	5-3
	Resistance and voltage readings	5-5	5-7
	Waveform analysis	5-6	5-7
	Adjustment of resistors R30 and R31	5-7	5-7
	Adjustment of resistors R32 and R33	5-8	5-11
6.	GENERAL SUPPORT TESTING PROCEDURES		
	General	6-1	6-1
	Tools and test equipment	6-2	6-1
	Physical tests and inspections	6-3	6-3
	Discharge, main charge, and topping charge test	6-4	6-5
	Test data summary	6-5	6-6
7.	DEPOT OVERHAUL STANDARDS		
	Applicability of depot overhaul standards	7-1	7-1
	Applicable references	7-2	7-1
	Test facilities required	7-3	7-1
	Tests	7-4	7-1
CHAPTER	8. SHIPMENT AND LIMITED STORAGE AND DEMOLITION OF MATERIEL TO PREVENT ENEMY USE		
Section	I. Shipment and limited storage		
	Disassembly of equipment	8-1	8-1
	Repackaging for shipment or limited storage	8-2	8-1
	II. Demolition of materiel to prevent enemy use		
	Authority for demolition	8-3	8-1
	Methods of destruction	8-4	8-2
APPENDIX	A. REFERENCES		A-1
	B. BASIC ISSUE ITEMS (Nonapplicable)		
	C. MAINTENANCE ALLOCATION		C-1

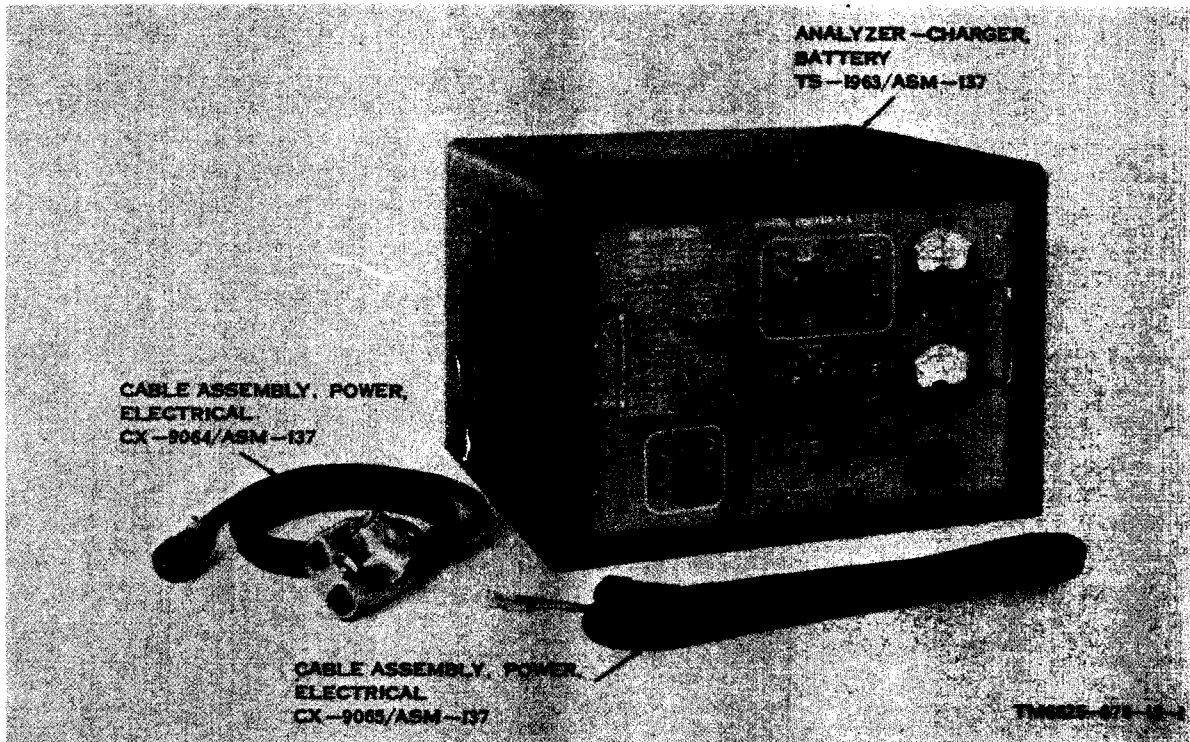

Figure 1-1. Analyzer-Charger, Battery AN/ASM-137

CHAPTER 1 INTRODUCTION

Section I. GENERAL

1-1. Scope

This manual describes Analyzer-Charger, Battery AN/ASM-137 (fig. 1-1) and provides instructions for operation and organizational, direct and general support, and depot maintenance. Also included is a discussion of the functioning of Analyzer-Charger, Battery AN/ASM-137. Analyzer-Charger, Battery AN/ASM-137 is referred to as the *analyzer-charger* in this manual. This manual also contains a maintenance allocation chart (app C) and an organizational, direct support, general support, and depot maintenance repair parts list (app D). Appendix D is current as of 24 January 1968.

1-2. Indexes of Publications

a. *DA Pam 310-4.* Refer to the latest issue of DA Pam 310-4 to determine whether there are new editions, changes, or additional publications pertaining to the equipment.

b. *DA Pam 310-7.* Refer to DA Pam 310-7 to determine whether there are modification work orders (MWO'S) pertaining to the equipment.

1-3. Forms and Records

a. *Reports of Maintenance and Unsatisfactory Equipment.* Maintenance forms, records, and reports which are to be used by maintenance personnel at all maintenance levels are listed in and prescribed by TM 38-750.

b. *Report of Packaging and Handling Deficiencies.*

Fill out and forward DD Form 6 (Packaging Improvement Report) as prescribed in AR 700-58/NAVSUPINST 4030.29/AFR 71-13/MCO P4030.29A, and DSAR 4145.8.

c. *Discrepancy in Shipment Report (DISREP) (SF 361).* Fill out and forward Discrepancy in Shipment Report (DISREP) (SF 361) as prescribed in AR 55-38/NAVSUPINST 4610.33A/AFR 75-18/MCO P4610.19B and DSAR 4500.15.

1-3.1. Reporting of Errors

Reporting of errors, omissions, and recommendations for improving this manual by the individual user is encouraged. Report should be submitted on DA Form 2028 (Recommended Changes to Publications and Blank Forms) and forwarded direct to Commander, US Army Electronics Command, ATTN: DRSEL-MA-Q, Fort Monmouth, NJ 07703.

1-3.2. Reporting Equipment Improvement Recommendations (EIR)

EIR will be prepared using DA Form 2407, Maintenance Request. Instructions for preparing EIR's are provided in TM 38-750, The Army Maintenance Management System. EIR's should be mailed direct to Commander, US Army Electronics Command, ATTN: DRSEL-MA-Q, Fort Monmouth, New Jersey 07703. A reply will be furnished direct to you.

Section II. DESCRIPTION AND DATA

1.4. Purpose and Use

Analyzer-Charger, Battery AN/ASM-137 is a portable instrument designed to automatically discharge, charge, and analyze aircraft batteries of the nickel-cadmium type. The AN/ASM-137 provides a go or no-go test for Batteries, Storage BB-432/A, and BB-434/A.

1-5. Technical Characteristics

Power input:
 Voltage 115 volts ± 10 percent
 Frequency 60 cps.
 Phase Single.

Current (maximum)	10 amperes.
Power output:	
Type of charging	Pulsing constant current.
Operating cycle (timed).	2-hour discharge followed by 4-hour charge.
MAIN CHARGE	5.5 amperes for BB-432/A.
current (constant).	15 amperes for BB-433/A.
	11 amperes for BB-434/A.
	(In addition, 2.3 and 1.5 amperes are available.)
TOPPING charge	2.2 amperes for BB-432/A.
current(constant).	8.5 amperes for BB-433/A.
	4.4 amperes for BB-434/A.
	(In addition 1.7, and 1.1 amperes are available.

TM 11-6625-678-15

Ambient operating temperature. From 35° to 120° F.
 Weight 100 pounds.

1-6. Description
 (fig. 1-1)

a. The AN/ASM-137 is a portable unit mounted in a self-contained cabinet. All operating controls, condensed operating instructions, direct-current (dc) ammeter, dc voltmeter, and receptacle for interconnecting the AN/ASM-137 with the battery under test are on the front panel. Vents in the side panels of the cabinet permit forced air circulation, and thus provide the necessary cooling. These vents must remain free from obstructions during operation.

b. Cable Assemblies, Power, Electrical CX9064/ASM-137 or CX-9065/ASM-137, used to connect the AN/ASM-137 to the battery under test, are stored in a tray in the upper left portion of the unit. Access to the tray is provided through a removable cover at the top of the cabinet.

1-7. Items Comprising an Operable Equipment
 (fig. 1-1)

The items listed in table 1-1 make up an operable Analyzer-Charger AN/ASM-137. One copy of TM 11-6625-678-15 is packed with each AN/ASM-137.

Table 1-1. Items Comprising an Operable Equipment

NSN	Nomenclature	Quantity	Dimensions (in.)		Width	Weight (lb)
			Height	Depth		
6130-00-921-3716	Analyzer-Charger Battery TS-1963/ASM-137	1	14-1/2	18	21-1/2	100
6130-00-914-9458	Cable Assembly, Power Electrical CX-9046/ASM-137	1	7 ft 6 in.			5
6130-00-914-9456	Cable Assembly, Power Electrical CX-9065/ASM-137	1	7 ft 6 in.			5

CHAPTER 2

INSTALLATION AND OPERATING INSTRUCTIONS

Section I. SERVICE UPON RECEIPT OF EQUIPMENT

2-1. Unpacking

a. Packaging Data. When packed for shipment, Analyzer-Charger, Battery AN/ASM-137 is placed in a carton and packed in a wooden packing crate. A typical wooden packing crate and its contents are shown in figure 2-1. The dimensions of the wooden packing crate are 31 1/4 by 23 1/4 by 27 inches, its volume is approximately 11.4 cubic feet, and its weight 180 pounds.

b. Removing Contents.

Caution: Do not attempt to pry off the top and side; equipment damage may result.

- (1) Cut and fold back the metal straps.
- (2) Remove the nails from the top of the wooden packing crate with a nail-puller. The top of the crate is marked OPEN HERE. Remove the top.
- (3) Remove the sheet of rubberized curled hair from the top of the carton.
- (4) Open the top of the carton containing the equipment.
- (5) Remove the sealed envelope containing the technical manual.
- (6) Remove the panel frame and the sheet of kraft paper covering the front panel.
- (7) Remove the corrugated fiberboard pads placed around the four sides of the equipment.
- (8) Remove the equipment.

2-2. Checking Unpacked Equipment

a. Inspect the equipment for damage incurred during shipment. If the equipment has been damaged, report the damage on DD Form 6 (para 1-3).

b. See that the equipment is complete as listed on the packing slip. If a packing slip is not available, check the equipment against the basic issue items list (app B). Report all discrepancies in accordance with TM 38-750. Shortage of a minor assembly or part that does not affect proper functioning of the equipment should not prevent use of the equipment.

c. If the equipment has been used or reconditioned, see whether it has been changed by a modification work order (MWO). If the equipment has been modified, the MWO number will appear on the front panel near the nomenclature plate. See that any operational instruction changes resulting from the modification have been entered in the equipment manual.

Note. Current MWO's applicable the the equipment are listed in DA Pam 310-7.

2-3. Installation of Equipment

Installation of the AN/ASM-137 includes the replacement of items that were removed from the equipment for shipment. Install the equipment in accordance with the instructions given below.

a. Remove the top cover of the equipment by unfastening the captive screw.

b. Remove the tray from the cabinet by unscrewing the four screws holding the tray in place.

c. Remove four rubber feet with mounting screws from their wrapping bags in the tray and install them at the bottom of the equipment cabinet.

d. Remove the cotton twine attaching the alternating-current (ac) line cord to the transformer brace.

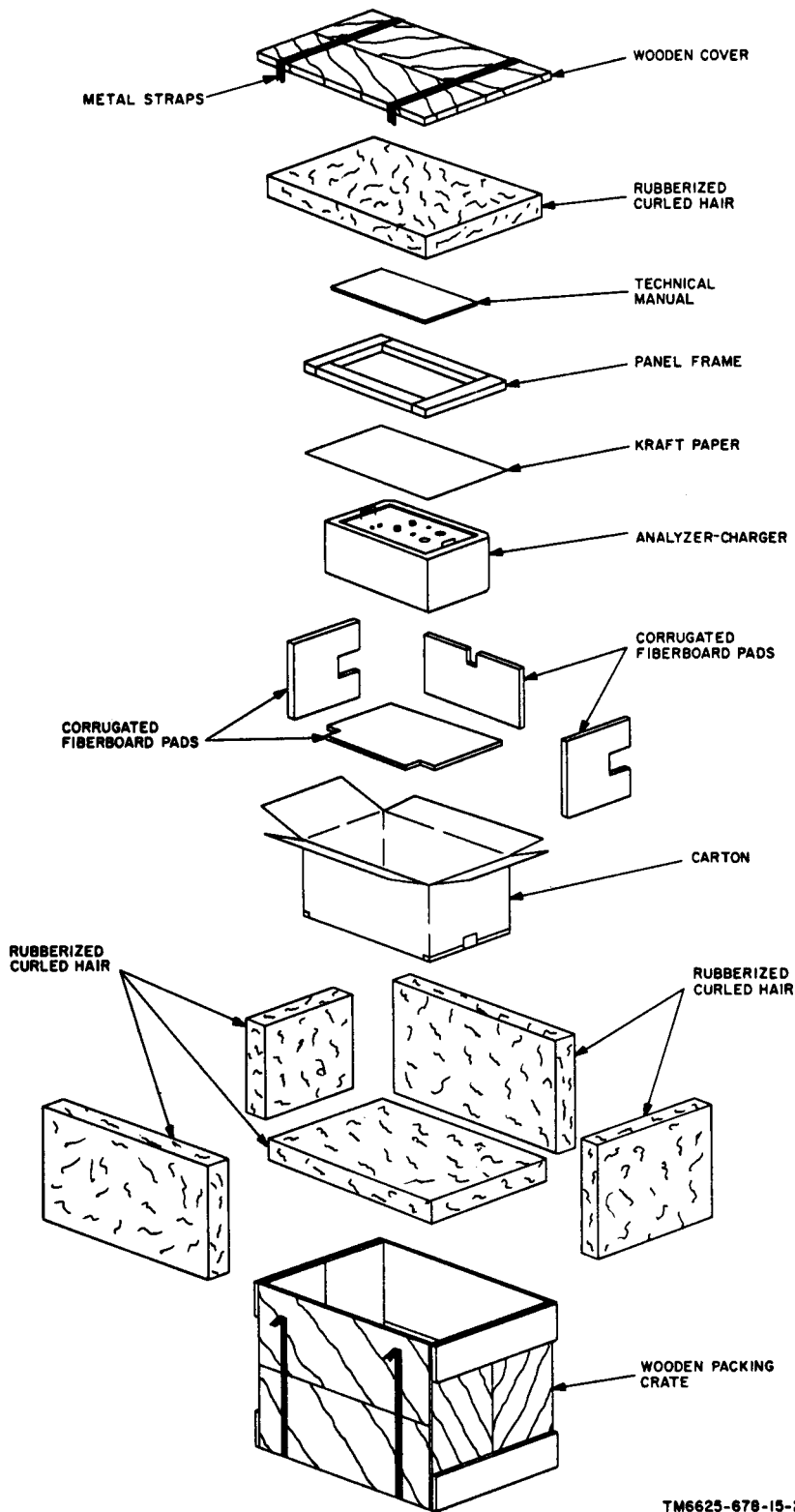

TM6625-678-15-2

Figure 2-1. Packaging diagram.

e. Remove the eight screws, holding the transformer brace, from the rear of the cabinet. Remove the brace from the cabinet.

f. Pull the ac line cord through the hole in the rear panel so that the entire free length of the cord is outside the cabinet

g. Remove all the running spares from the tray.

h. Cut the cotton twine and remove the two cable assemblies from the tray. Remove wrapping paper from the cable connector and replace the two cables in the tray.

i. Remove relays K1 and K4 from the tray. Remove the wrapping paper and install the relays in the proper sockets (fig. 5-2).

j. Replace the tray in the cabinet and fasten it with the four screws removed in b above.

Section II. OPERATION

2-4. Controls and Indicators (fig. 2-2)

The following chart lists the analyzer-charger controls and indicators and their functions:

Control or indicator	Function
TIMER switch-----	Selects the mode of operation and the time cycle.
	Position Action
	(S) DISCHARGE Starts automatic discharge and charge-analyze cycle. Battery under test will discharge for 2 hours while TIMER switch advances to (2)
	(2) MAIN CHARGE Starts main charge (2 hours) while TIMER switch advances to (4)
	(4) TOPPING Starts topping charge (2 hours) while TIMER switch advances to (6)
	(6) OFF The AN/ASM-137 discharge and charge-analyze cycle turns off when TIMER switch advances to (6).
END OF CYCLE indicator lamp-----	When illuminated, indicates that battery under test is in good condition after programed charge-analyze cycle.
BATTERY LOW indicator lamp-----	When illuminated, indicates that battery under test is in no-go condition during programed discharge portion of charge-analyze cycle.
Ammeter-----	Indicates value of charge current to right of zero and value of discharge current to left of zero.
Voltmeter -----	Indicates output voltage.
BATTERY CABLE connector-----	Connects battery under test connection to AN/ASM-137 by means of cable assembly supplied.
AUTOMATIC CYCLE-MANUAL DISCHARGE switch.	In the AUTOMATIC CYCLE position, enable the AN/ASM-137 to cycle automatically. In the MANUAL DISCHARGE position, programed analyze-charge cycle stops and enables the AN/ASM-137 to discharge battery under test.

Control or indicator	Function
SELECTOR switch -----	Selects the required internal circuitry for the type of battery to be tested.
AC POWER FUSE -----	Protects the equipment from damage caused by excessive current.
AC POWER ON-OFF switch -----	In the ON position, applies ac input power to the AN/ASM-137.
AC POWER indicator lamp -----	In the OFF position, turns off ac input power. When illuminated, indicates that ac input power is applied.

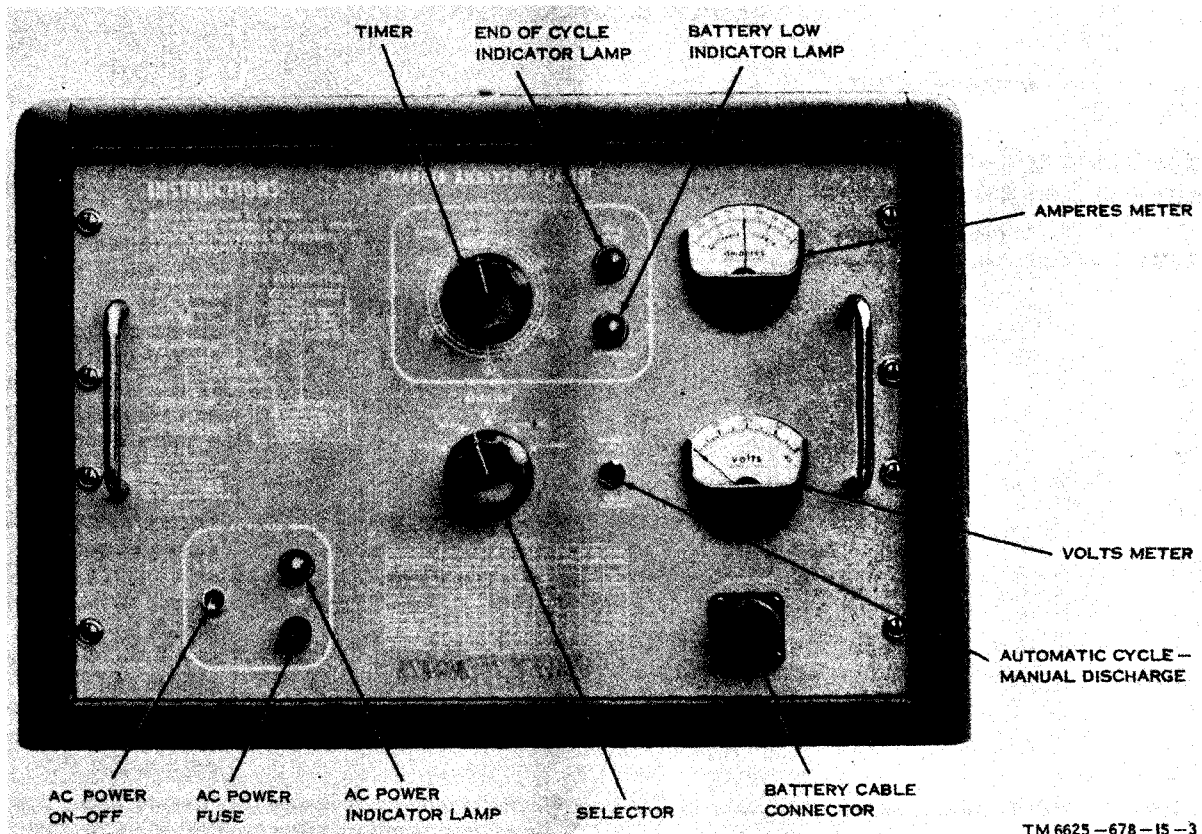

Figure 2-2. Analyzer-Charger, Battery AN/ASM-137, controls and indicators.

2-5. Starting Procedure

Start the equipment as follows (a through f below):

- a. Set the AC POWER ON-OFF switch to OFF and the TIMER switch to (6) OFF.
- b. Connect Cable Assembly, Power, Electrical CX-9064/ASM-137 to the BATTERY CABLE connector on the AN/ASM-137 and

the terminals of the battery being tested. (There is no requirement to use Cable Assembly, Power, Electrical CX-9065/ASM-137.)

- c. Connect the ac input power cable from the AN/ASM-137 to the 115-volt 60-cycle-per-second (cps) power source. Be sure vents of the cabinet side panels are not obstructed.

d. Set the SELECTOR switch to the appropriate position for the battery being tested as follows:

NOTE

There are no requirements to use positions MA300H and M-500H.

<i>Battery under test</i>	<i>SELECTOR switch position</i>
---------------------------	---------------------------------

BB-432/A	MA-4
BB-433/A	MA-5
BB-434/A	MA-7

e. Set the AUTOMATIC CYCLE-MANUAL DISCHARGE switch to AUTOMATIC CYCLE.

f. Set the AC POWER ON-OFF switch to ON. The red AC POWER indicator lamp and the yellow END OF CYCLE indicator lamp illuminate.

2-6. Operating Procedure

Start the equipment as instructed in paragraph 2-5 and proceed as follows:

a. Set the TIMER switch to (S) DISCHARGE. The yellow END OF CYCLE indicator lamp extinguishes. The battery under test will discharge for 2 hours while the TIMER automatically advances clockwise. The discharge current for BB-432/A is between 9 and 13 amperes. The discharge current for BB-433/A is between 14.5 and 19.5 amperes. The discharge current for BB-434/A is between 4-5 and 6.5 amperes.

b. At the end of the DISCHARGE period, the cycle automatically continues if the BATTERY LOW pilot indicator lamp does not illuminate and the TIMER has advanced to (2) MAIN CHARGE. The TIMER advances automatically during the main charge, which takes 2 hours. The main charge current for BB-432/A is between 5 and 6 amperes. The main charge current for BB-433/A is between 14 and 16 amperes. The main charge current for BB-434/A is between 10 and 12 amperes. If the BATTERY LOW INDICATOR LAMP illuminates, the battery under test has to be reconditioned and the automatic cycle and TIMER will stop. Proceed as directed in (1) through (5) below only if the BATTERY LOW indicator lamp illuminates.

(1) Set the AUTOMATIC CYCLE-MANUAL DISCHARGE switch to MANUAL DISCHARGE.

(2) Wait until the battery under test has discharged to less than 10 volts. The TIMER will not advance during this period.

(3) After the battery under test has discharged to less than 10 volts, set the AUTOMATIC CYCLE-MANUAL DISCHARGE switch to AUTOMATIC CYCLE.

(4) Set the TIMER switch to (2) MAIN CHARGE. The BATTERY LOW indicator light extinguishes. Automatic operation will resume in approximately 5 minutes, when the voltage of the battery under test reaches 19 volts.

(5) When automatic operation resumes, the TIMER switch should beat (2) MAIN CHARGE. The TIMER advances automatically during the main charge, which takes 2 hours. The main charge current for BB-432/A is between 5 and 6 amperes. The main charge current for BB-433/A is between 14 and 16 amperes. The main charge current for BB-434/A is between 10 and 12 amperes.

c. At the end of the main charge period, the TIMER has advanced to (4) TOPPING. At this period, the topping charge begins and continues for 2 hours. The topping charge current for BB-432/A is between 2 and 3 amperes. The topping charge current for BB-433/A is between 7.5 and 9.5 amperes. The topping charge current for BB-434/A is between 4 and 5 amperes.

NOTE

Do not return battery to service unless a full automatic cycle has been completed on the AN/ASM-137 and the END OF CYCLE indicator lamp is illuminated. A full automatic cycle is *only* completed when the battery under test goes through a 2-hour discharge period, a 2-hour MAIN CHARGE period, and a 2-hour TOPPING charge period. The battery under test requires repair if it fails to go through a full automatic cycle.

d. At the completion of the charge-analyze cycle, the TIMER has advanced to (6) OFF. The AN/ASM-137 shuts itself off and the yellow END OF CYCLE indicator lamp illuminates. The battery under test is now ready to return to service.

2-7. Stopping Procedure

The AN/ASM-137 shuts itself off automatically when the TIMER advances to (6) OFF. To shut down the equipment completely, proceed as follows:

- a.* Set AC POWER ON-OFF switch to OFF.
- b.* Disconnect the power cable from the ac power source.
- c.* Disconnect the CX-9064/ASM-137 from the BATTERY CABLE connector and from the terminals of the battery tested.

CHAPTER 3

OPERATOR AND ORGANIZATIONAL MAINTENANCE

3-1. Scope of Maintenance

The maintenance duties assigned to the operator and organizational repairman for the AN/ASM-137 are listed below, together with a reference to the paragraphs covering the specific maintenance functions. Tools and test equipment required for maintenance are listed in appendix C.

- a. Operator's daily preventive maintenance checks and services chart (para 3-4).
- b. Operator's weekly preventive maintenance checks and services chart (para 3-5).
- c. Organizational monthly preventive maintenance checks and services chart (para 3-6).
- d. Organizational quarterly preventive maintenance checks and services, chart (para 3-7).
- e. Cleaning (para 3-8).
- f. Touchup painting (para 3-9).
- g. Troubleshooting (para 3-10 and 3-11).
- h. Replacement of indicator lamps and fuse (para 3-12).

3-2. Preventive Maintenance

Preventive maintenance is the systematic care, servicing, and inspection of the AN/ASM-137 to prevent occurrence of trouble, reduce downtime, and insure that the equipment is serviceable.

a. *Systematic Care.* Procedures given in paragraphs 3-4 through 3-6 cover routine systematic care and cleaning essential to the proper upkeep and operation of the equipment

b. *Preventive Maintenance Checks and Services.* The preventive maintenance checks and services charts (para 3-4 through 3-7) outline functions to be performed at specific intervals. These checks and services are to maintain Army electronic equipment in a combat-serviceable condition; that is, in good general (physical) condition and in good operating condition. To assist operators in maintaining combat serviceability, the chart indicates what to check, how to check, and the normal indications. The *references* column lists the paragraphs or manuals that contain detailed repair or replacement procedures. If the defect cannot be remedied by performing the corrective actions listed, a higher category of maintenance or repair is required. Records and reports of these checks and services must be made in accordance with requirements given in TM 38-750.

3-3. Preventive Maintenance Checks and Services Periods

Preventive maintenance checks and services of the equipment are required daily, weekly, monthly, and quarterly. Paragraph 3-4 specifies the checks and services that must be accomplished daily (or at least once a week if the equipment is maintained in a standby condition). Paragraphs 3-5, 3-6, and 3-7 specify additional checks and services that must be performed on a weekly, monthly, and quarterly basis, respectively.

34. Operator's Daily Preventive Maintenance Checks and Services Chart

Sequence No.	Item to be inspected	Procedure	Reference
1	Completeness-----	Check to see that equipment is complete.	Appendix B.

Sequence No.	Item to be inspected	Procedure	Reference
2	Exterior surfaces-----	Clean exterior surfaces, including panel and meter glasses. Check all meter glasses and indicator lenses for cracks.	Para 3-8.
3	Connectors-----	Check tightness of all connectors.	None.
4	Controls and indicators.	While making operating checks (item 5), check to see that the mechanical action of each switch is smooth and free of external or internal binding, and that there is no excessive looseness. Also, check meters for sticking or bent pointers.	None.
6	Operation-----	During operation, be alert for any abnormal indication.	Para 2-6.

3-5. Operator's Weekly Preventive Maintenance Checks and Services Chart

Sequence No.	Item to be inspected	Procedure	Reference
1	Cable-----	Inspect cables for chafed, cracked, or frayed insulation. Replace connector that is broken, arced, stripped, or excessively worn.	None.
2	Metal surfaces-----	Inspect exposed metal surfaces for rust and corrosion; clean and touchup paint as required.	Para 3-9.
3	Handles-----	Inspect handles for looseness; replace or tighten, as necessary.	

3-6. Organizational Monthly Preventive Maintenance Checks and Services Chart

Sequence No.	Item to be inspected	Procedure	Reference
1	Transformer terminals.	Inspect terminals on power transformer. All nuts must be tight. There should be no evidence of dirt or corrosion.	None.
2	Terminal blocks-----	Inspect terminal blocks for loose connections and cracked or broken insulation.	None.
3	Resistors and capacitors.	Inspect resistors and capacitors for cracks, blistering, or other defects.	None.
4	Gaskets and insulators.	Inspect gaskets, insulators, bushings, and sleeves for cracks, chipping, and excessive wear.	None.
5	Interior-----	Clean interior of chassis and cabinet.	Para 3-8.

3-7. Organizational Quarterly Preventive Maintenance Checks and Services Chart

Sequence No.	Item to be inspected	Procedure	Reference
1	Publications-----	See that all publications are complete, serviceable, and current.	DA Pam 310-4.
2	Modifications-----	Check DA Pam 310-7 to determine whether new applicable MWO's have been published. All URGENT MWO's must be applied immediately. All NORMAL MWO's must be scheduled.	TM 38-750 and DA Pam 310-7

3-8. Cleaning

Inspect the exterior of the equipment; exterior surfaces should be free of dust, dirt, grease, and fungus.

a. Remove dust and loose dirt with a clean, soft cloth.

Warning: Prolonged breathing of cleaning compound is dangerous; be sure adequate ventilation, is provided. Cleaning compound is flammable; do not use near a flame. Avoid contact with the skin; wash off any that spills on your hands.

b. Remove grease, fungus, and ground-in dirt from the case; use a cloth dampened (not wet) with cleaning compound (FSN 7930-395-9542).

c. Remove dust or dirt from the BATTERY CABLE connector and CX-9064/ASM-137 cable connectors with a brush.

Caution: Do not press on the meter faces (glasses) when cleaning; meters may become damaged.

d. Clean the control panel and meters with a soft, clean cloth. If necessary, dampen the cloth with water; mild soap may be used for more effective cleaning.

3-9. Touchup Painting Instructions

a. *Rustproofing.* When the finish on the AN/ASM-137 has become badly scarred or damaged, rust and corrosion can be prevented by touching up the bare surfaces. Use No. 000 sandpaper to clean the surface down to the bare metal. Obtain a bright, smooth finish.

b. *Painting.* Remove rust and corrosion from metal surfaces by lightly sanding them with fine sandpaper. Brush two thin coats of paint on the bare metal to protect it from further corrosion. Refer to the applicable cleaning and refinishing practices specified in TB SIG 364.

3-10. General Troubleshooting Information

Caution: When troubleshooting the AN/ASM-137, be sure that the ac power input cable connector is connected to a polarized, three-pin socket so that the chassis will be grounded to the input power source.

Troubleshooting the AN/ASM-137 at the organizational category is based on an operational check. To troubleshoot the AN/ASM-137, perform the operation functions until an abnormal indication or result is observed; then, perform checks and corrective actions indicated in the troubleshooting chart. If the corrective measures indicated do not result in the correction of the trouble, higher maintenance category repair is required.

3-11. Organizational Troubleshooting Chart

Item No.	Trouble symptom	Probable trouble	Checks and corrective measures
1	AC POWER indicator lamp does not illuminate when AC POWER switch is set to ON.	Defective AC POWER fuse or AC POWER indicator lamp.	Replace fuse or lamp (para 3-12).

TM 11-6625-678-15

Item No.	Trouble symptom	Probable trouble	Checks and corrective measures
2	Ammeter does not indicate charging or discharging current.	Ammeter is defective.	Higher maintenance category repair is required.
3	Voltmeter does not indicate charging or battery voltage.	Voltmeter is defective.	Higher maintenance category repair is required.
4	Appropriate indicator lamp does not illuminate as required.	Defective indicator lamp.	Replace indicator lamp (para 3-12).

3-12. Replacement of Indicator Lamps and Fuse

a. Replacement of Indicator Lamps.

- (1) Unscrew and remove lens.
- (2) Press in on the indicator lamp and turn it counterclockwise to unlock.
- (3) Pull the defective indicator lamp out and replace it with a new one.
- (4) Push the indicator lamp in and twist it clockwise to lock.

- (5) Replace lens and screw it back on tightly.

b. Replacement of Fuse.

- (1) Press in on fuseholder and turn it counterclockwise to unlock.
- (2) Remove defective fuse (12-ampere, 250-volt cartridge type) from fuseholder and replace it with a new one.
- (3) Replace fuseholder and lock it in place.

CHAPTER 4

FUNCTIONING OF EQUIPMENT

4-1. Block Diagram (fig. 4-1)

Analyzer-Charger, Battery AN/ASM-137 consists of an input circuit, passing-regulator circuit and charge resistor bank, timer-programmer circuit, and discharge resistor bank.

a. The input circuit consists of a power transformer and its rectifier circuits which supply the dc battery charging current and the power for the timer-programmer circuit.

b. The passing-regulator circuit is in series with the input circuit and with the battery under test. Charging current is applied to the battery under test in the form of short-duration, high-amplitude current pulses, generated by an oscillator in the passing-regulator circuit. The magnitude of the average charging current applied to the battery depends on the duration of the current pulses. For example, the longer the pulse duration, the greater the average charging current. Regulation of the charging current is accomplished by automatically varying the duration of the current pulses with variations in input voltage and battery voltage. Two types of charging currents are applied to the battery; the main charge, consisting of longer duration current pulses, followed (after a programmed time interval), by the topping charge, consisting of shorter duration current pulses and therefore resulting in a smaller magnitude average charging current (fig. 4-2). The topping current level is also maintained constant by the regulating action of the passing-regulator circuit, which changes the current pulses duration with variations in line power.

c. The timer-programmer provides a timed discharge, followed by a timed main charge, and then a timed topping charge cycle. For each cycle, resistors are automatically connected

as required to attain the desired charging and discharging current values.

4-2. Input Circuit (fig. 8-3)

a. The input circuit of the AN/ASM-137 consists of power transformer T1; full-wave rectifier diodes CR1 and CR2 which supply the dc battery charging current; half-wave rectifier diode CR10, which supplies the triggering pulse to the passing-regulator circuit; and an additional secondary winding on T1, which provides 117-volt ac unregulated power.

b. Input power of 115-volts, single-phase, 60 cps is applied to the primary winding of power transformer T1 through the closed contacts of AC POWER ON-OFF switch S1. The equipment is protected against overload by fuse F1 and is cooled by blower motor B1. AC POWER indicator lamp DS1 indicates that input power is applied to the unit. Transformer T1 has three secondary windings.

- (1) Ac power in one secondary winding (terminals 3, 4, and 5) of T1 is converted to dc charging current by full-wave rectifier diodes CR1 and CR2, filtered by capacitor C1, and applied to the passing-regulator circuit through the closed contacts (terminals 3 and 6) of charge contactor K3. Diodes CR1 and CR2 are mounted on a heat sink for heat dissipation.
- (2) A second secondary winding (terminals 6 and 7) of transformer T1 powers a trigger circuit, which consists of half-wave rectifier diode CR10 and pi-type differentiator network consisting of capacitor C2 and resistors R3 and R14. A trigger pulse, gener-

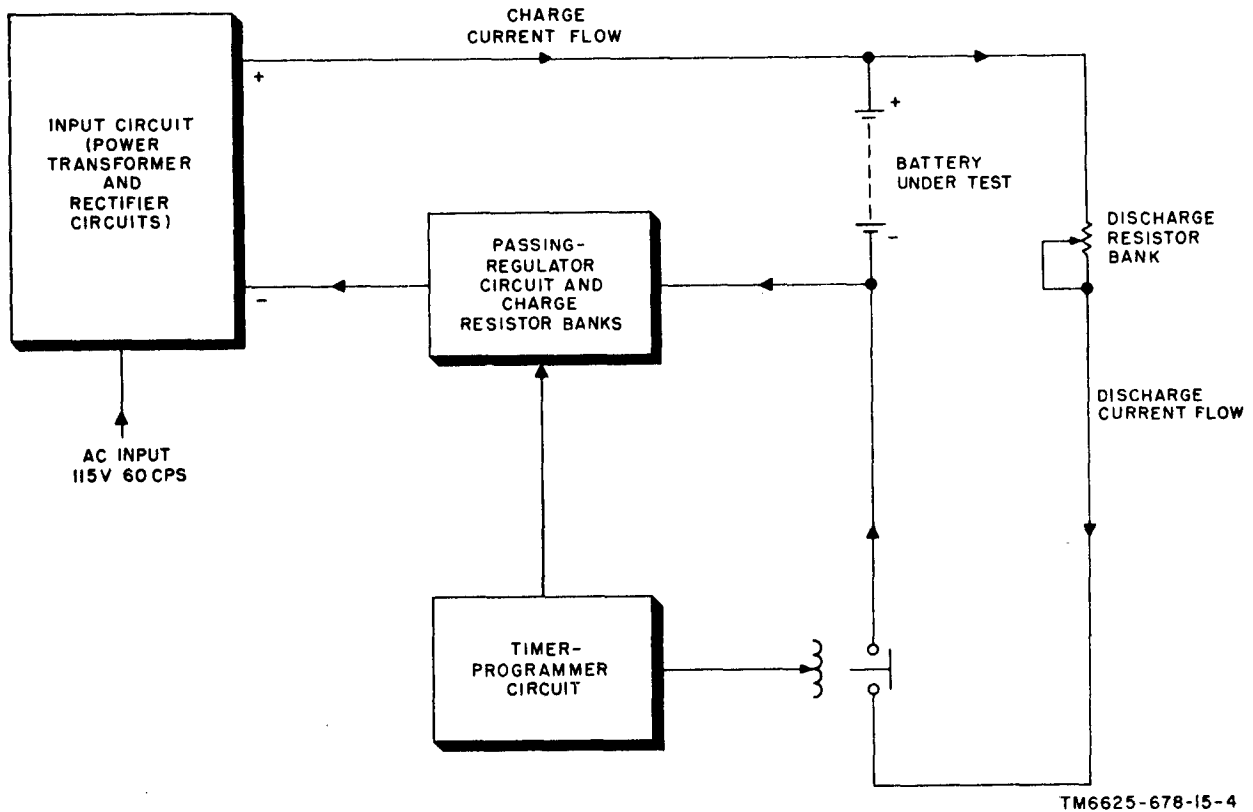

Figure 4-1. Analyzer-Charger, Battery AN/ASM-137, block diagram.

ated once during each cycle of applied ac power, is fed to the emitter of oscillator transistor Q1 in the passing-regulator circuit.

- (3) A third secondary winding (terminals 8 and 9) of transformer T1 provides 117-volt ac power for the timer, relays, and indicator lamps.

4-3. Passing-Regulator Circuit (fig. 8-3)

a. The passing-regulator circuit (fig. 4-3), consists of an oscillator stage (transistor Q1) and transistor follower stage (transistors Q2 and Q3). The passing-regulator circuit is in series with the dc charging current and the negative terminal of the battery under test. This circuit generates the short-duration, high-amplitude charging current pulses applied to the battery, and maintains the average charging current constant with variations in line voltage.

Transistors Q1, Q2, and Q3, as well as diodes CR3 and CR4 which provide proper off-biasing for Q2 and Q3, are mounted on a heat sink for heat dissipation. Resistors R2 and R3 are current limiting and collector load resistors for transistors Q2 and Q3, respectively. Resistors R4 and R5 set the magnitude of base current for transistors Q2 and Q3, respectively.

b. Oscillator transistor Q1 is driven into conduction by a trigger pulse applied to the emitter of Q1 from differentiator network R13, C2, and R14 once during each cycle of applied ac power. The conduction of Q1 causes followers Q2 and Q3 to conduct when SELECTOR switch S2 is at MA-5 or MA-4. Followers Q2 and Q3 are parallel-connected to carry the heavy current load in the MA-5 and MA-4 positions of S2 safely. When S2 is at MA-7, MA-300H, or MA-500H, followers Q2 and Q3 are biased to cutoff by resistor R12, and the total current load is carried by

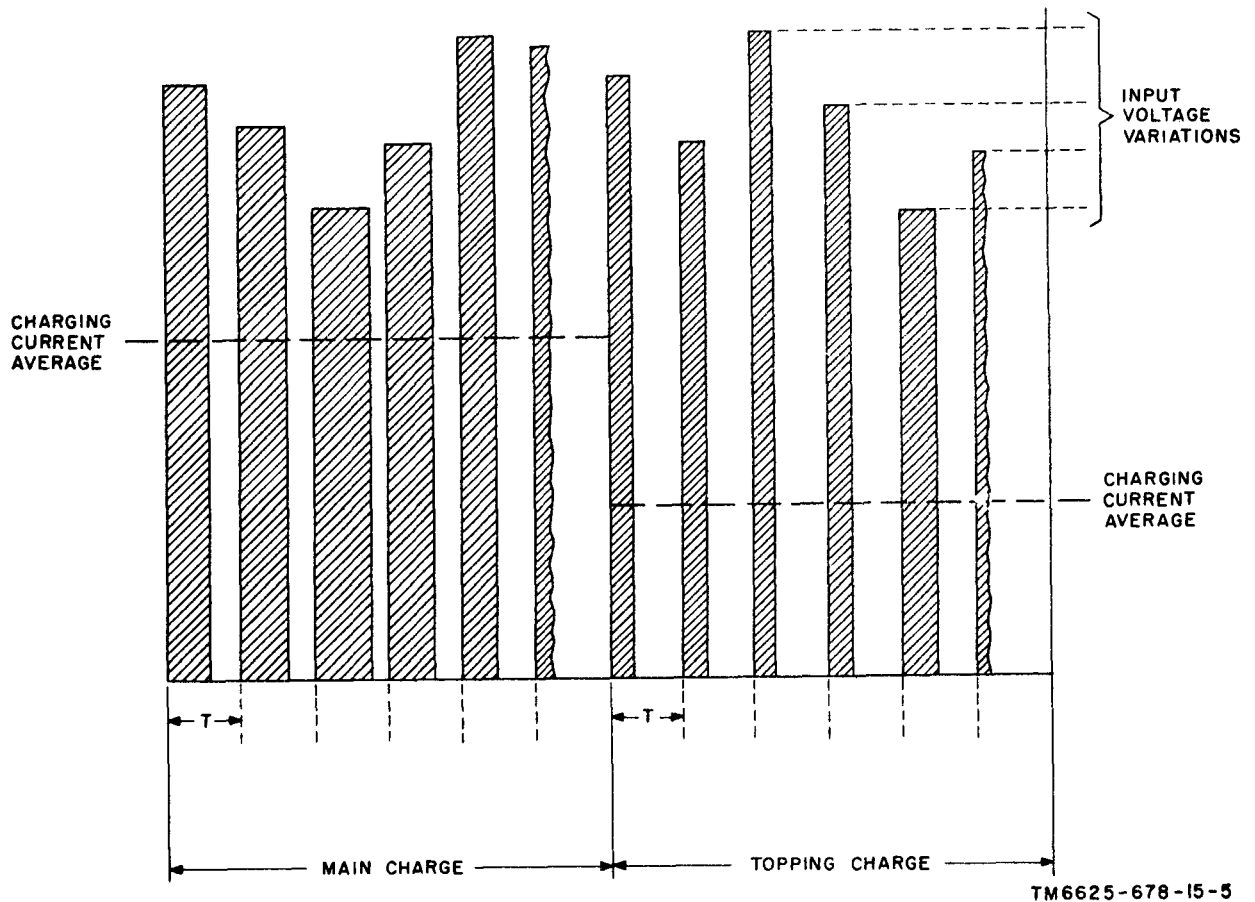

Figure 4-2. Charging current action.

Q1. Conduction of Q1 causes current to flow through the primary (terminals 1 and 2) of transformer T2 and resistor R1, as well as through the base circuit of Q1. The current from the base of Q1 flows through biasing diodes CR8 and CR9, either the high rate or the low rate resistor bank depending on the setting of TIMER switch S4, and the secondary winding of T2. The duration of the charging current pulses produced by the passing-regulator circuit depends upon the time it takes for T2 to saturate.

c. Transformer T2 is a saturable reactor device. The speed with which it saturates during each cycle depends upon algebraic summation of the flux produced by the primary and secondary currents in T2. The current flowing in the secondary winding (terminals 3 and 4) of T2 is controlled by the high rate resistor

bank (during the main charge) or the low rate resistor bank (during the topping charge). This current flowing through the T2 secondary produces a flux which subtracts from the flux produced by the primary winding of T2. During the main charge, the high rate resistor bank, consisting of lower value resistors, is connected into the circuit, resulting in a greater current flow through the secondary of T2. Since the total flux produced by the primary and secondary currents is reduced by the flux generated from the secondary current alone, the total flux becomes smaller as the current in the secondary winding increases. Transformer T2, therefore, takes longer to saturate and the complete circuit conducts over a longer period of time, resulting in wider charging current pulses and hence in a larger average charging current. Conversely, when the low rate resistor

bank, used during the topping charge is switched into the circuit, a lower current flow through the secondary of T2. The total flux generated in T2 becomes larger, and T2 saturates in a shorter period of time, resulting in narrower charging current pulses and, therefore, in a smaller average charging current, as illustrated in figure 4-2. Diodes CR7 and resistor R28, connected in series across terminals 3 and 4 of transformer T2, damp out transient voltages.

d. Regulation of the charging current with variations of input voltage is accomplished automatically. Assume the charging current applied to the passing-regulator circuit from charge contactor K3 increases. This increase in applied current causes increased current flow through the primary winding of T2. The flux generated in T2 becomes larger, and T2 saturates in a shorter period of time, resulting in narrower

charging current pulses and, therefore, in a smaller average charging current. Conversely, if the charging current applied to the passing-regulator circuit from K3 decreases, the same regulating action results in wider charging current pulses and, therefore, in a larger average charging current. This regulating section takes place with both the wider main charge current pulses and the narrower topping charge pulses.

e. Thermistor TH1 protects the unit against overheating. Since TH1 has a negative resistance coefficient, its resistance decreases with an increase in temperature. When the temperature exceeds 120°F, the resistance of TH1 decreases. Ballast resistor R29, connected in series with thermistor TH1, limits the maximum reverse bias applied to transistor Q1 when the resistance of thermistor TH1 decreases to a low value.

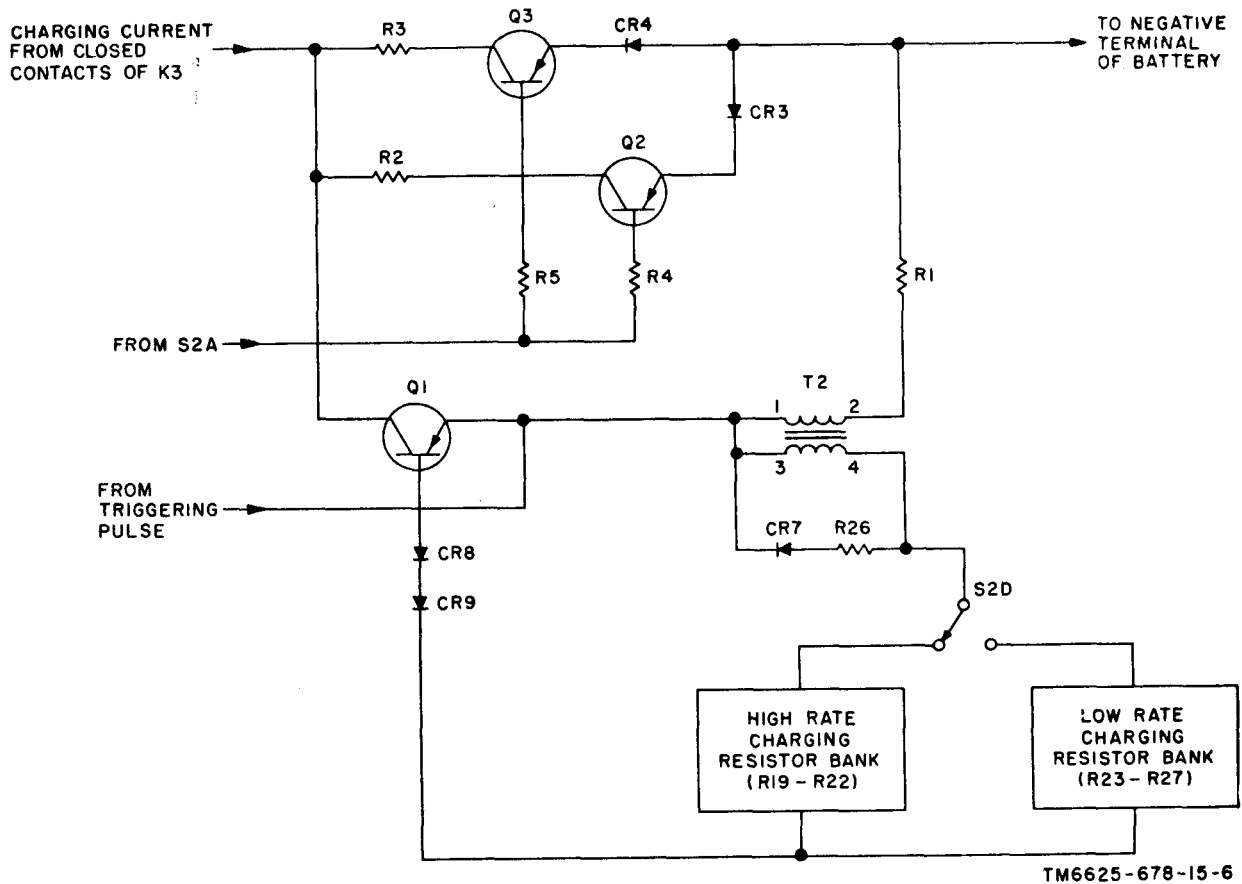

Figure 4-3. Passing-regulator circuit, simplified schematic.

4-4. Timer-Programmer Circuit (fig. 8-3)

a. The timer-programmer consists of a 6-hour, ac timing motor B2 and switches S4-A through S4-D. Timing motor B2 operates switches S4-A through S4-D and thus completes the discharge, main charge, or topping charge circuits, depending on the position of B2. The functioning of S4 is illustrated in figure 4-4, which shows the effect of each switch section on the operating cycle. With timer B2 positioned under 2 hours, S4 closes the discharge circuit. Battery charging takes place at a high rate (main charge) when B2 is between 2 and 4 hours and at a low rate (topping charge) when B2 is between 4 and 6 hours of its 6-hour cycle. The automatic test cycle is started by setting the timer to (S) DISCHARGE. In this position of B2, S4-A is switched to position 2, S4-B to position 5, S4-C to position 8, and S4-D to position 11. With S4 thus positioned, the discharge circuit is closed, and discharge contactor K2, 19-volt dropout relay K1, and 19-volt pull-in relay K4 are energized. The battery under test, connected to BATTERY CABLE connector J2 by means of the appropriate cable assembly, discharges through SELECTOR switch S2, certain selected load resistors of discharge resistor bank R51 through R55, and the closed contacts (pins 3 and 6) of discharge contactor K2. Selector S2 selects the appropriate discharge load resistors from the discharge resistor bank and switches them in parallel into the circuit to provide the proper discharge current for the particular battery under test. The discharge current is indicated on front panel ammeter M2, and the voltage at the terminals of the battery under test is indicated on voltmeter M1.

b. If the capacity of the battery under test is low and the voltage at its terminals falls below 19 volts, Zener diode CR13, in series with 19-volt dropout relay K1, stops conducting and K1 releases. The exact voltage level at which this release occurs is determined by the setting of variable resistor R30. Diode CR6 assures that current flow through Zener diode CR13 takes place in the reverse direction only, and thus provides protection against accidental

battery reversal. The release of K1 causes the BATTERY LOW indicator lamp to illuminate and the ac power to be disconnected from discharge contactor K2, thereby opening its contacts, and from timer motor B2, causing it to stop. To continue the battery test cycle, AUTOMATIC CYCLE-MANUAL DISCHARGE switch S3 is manually set to MANUAL DISCHARGE, which closes the discharge circuit again and reenergize discharge contactor K2, permitting the battery discharge to continue. Setting S3 to MANUAL DISCHARGE, also releases 19-volt pull-in relay K4. After the battery under test has discharged to less than 10 volts, the battery test cycle should be continued by manually resetting S3 to AUTOMATIC CYCLE and by advancing the timer to (2) MAIN CHARGE. In this position of B2, S4-A is switched to position 3 and S4-C to position 9; S4-B and S4-D remain in positions 5 and 11, respectively. With S4 thus positioned, the main charge circuit is closed and relay K1 is energized. In its released condition, 19-volt pull-in relay K4 connects the battery directly to the dc charging current circuit through resistor R6, bypassing the passing-regulator circuit. When the battery terminal voltage reaches 19 volts, 19-volt pull-in relay K4 energizes, which, in turn, causes charge contactor K3 to close. The exact voltage at which K4 energizes is determined by the setting of variable resistor R31. Diode CR5 permits current flow through K4 in one direction only, providing protection against accidental battery reversal. With K3 and K4 energized, the battery charge current is regulated by the passing-regulator circuit. The main charge current flows through high rate charging resistor bank R19 through R22. Variable resistor R32 permits readjustment of the main charge current. When timer B2 advances to (4) TOPPING, S4-D switches low rate charging resistor bank R23 through R27 into the circuit. Variable resistor R33 permits adjustment of the topping charge current.

c. If the battery under test is normal, timer B2 will automatically advance to (2) MAIN CHARGE, causing charge contactor K3 to close and the main charge current to start immediately after discharge. After 2 hours, timer B2

advances to (4) TOPPING, which switches to low rate charging resistor bank into the circuit to produce the topping charge current. At the end of the topping charge period, timer B2 causes S4-B to switch to position 6, stopping the charging current and causing the END OF CYCLE indicator lamp to illuminate. With switch S4-B in position 6 and a battery connected to the output, relays K1 and K4 energize and relays K2 and K3 deenergize.

4-5. Monitoring Circuit

Panel-mounted voltmeter M1 continuously indicates the battery terminal voltage. Battery charging or discharging current is indicated on zero-center, panel-mounted ammeter M2. Charge current is indicated to the right of zero and discharge current is indicated to the left of zero.

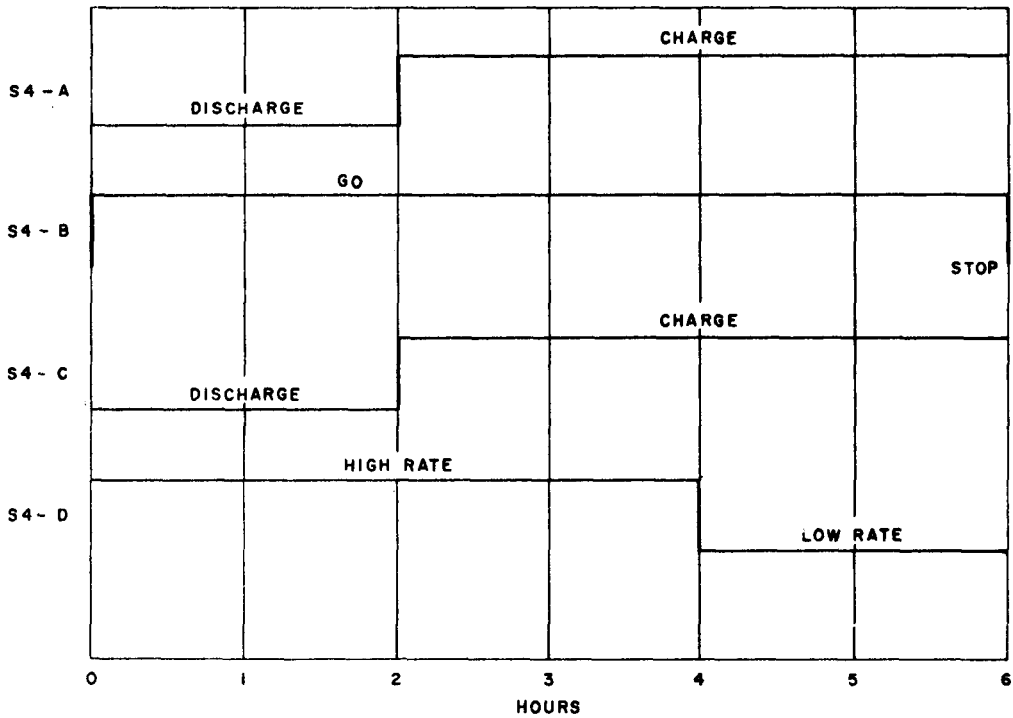

TM6625-678-15-7

Figure 4-4. Functioning of timer-programmer.

CHAPTER 5

TROUBLESHOOTING

Warning: When servicing the AN/ASM-37, be extremely careful of the high voltages and currents that exist in it. Serious injury or death may result from contact with the output terminals. Deenergize the equipment, and disconnect it from the input power source before performing any maintenance.

5-1. General Instructions

Troubleshooting at the direct support, general support, and depot maintenance categories includes all techniques given for organizational maintenance, and any special or additional techniques required to isolate a defective part.

5-2. Organization of Troubleshooting Procedures

a. General. The first step in servicing a defective AN/ASM-37 is to sectionalize the fault. Sectionalization means tracing the fault to a major circuit group of the AN/ASM-37, such as the input power circuit, the passing-regulator circuit, or the timer-programmer circuit. The second step is to localize the fault. Localization means tracing the fault to a defective stage of the circuit group responsible for the abnormal condition. The third step is isolation. Isolation means locating the defective component or part in the circuit stage. Some defective parts, such as burned resistors and arcing or shorted transformers, can often be located by sight, smell, and hearing; however, most defective parts must be isolated by checking voltages and resistances.

b. Sectionalization. The first step in tracing trouble is to determine the circuit group at fault by one of the following methods:

- (1) *Visual inspection.* The purpose of visual inspection is to locate faults without tasting or measuring circuits. All meter readings, or other visual indications, should be observed and an

attempt made to sectionalize the fault to a particular circuit group.

- (2) *Operational tests.* An operational test frequently indicates the general location of trouble. In many instances, the test will help to determine the exact nature of the fault. The operating procedures (para 2-5, 2-6, and 2-7), with the normally expected indications called out in the procedures, provide good operational tests

c. Localization. Localization procedures should be performed after the trouble has been sectionalized. The troubleshooting chart (para 5-4c) should be used in localizing the trouble to a suspected stage. The troubleshooting chart (para 5-4c) lists symptoms of common troubles and gives (or references) corrective measures. Such a chart cannot include all the trouble symptoms that may occur; the repairman should use the chart as a guide in analyzing symptoms that may not be listed.

Caution: Before using any ohmmeter to test transistors or transistor circuits, check the open-circuit voltage across the ohmmeter test leads. Do not use the ohmmeter if the open-circuit voltage exceeds 1.5 volts. Also, since the RX1 range normally connects the ohmmeter internal battery directly across the test leads, the comparatively high current (50 milliamperes (ma) or more) may damage the transistor under test. As a general rule, the RX1 range of any ohmmeter should not be used when testing low-powered transistors.

d. *Isolation.* After the fault has been localized to a stage by using the troubleshooting chart, voltage and resistance measurements and waveform checks should be made to isolate the defective component. A deviation of any appreciable amount from the voltage and resistance readings given in paragraph 5-5 will indicate a faulty part. The voltage checks will isolate the trouble to a group of parts, such as resistors, capacitors, and diodes; a resistance check will determine which part or component

is defective. Waveform data and analysis (para 5-6) are also given for the AN/ASM-37.

e. *Resistor and Capacitor Color Code Diagrams.* Color code diagrams for resistors and capacitors (fig. 8-1 and 8-2) provide pertinent resistance, voltage rating, and tolerance information.

f. *Component Locations.* Figures 5-1 through 5-8 show the component locations of the AN/ASM-137.

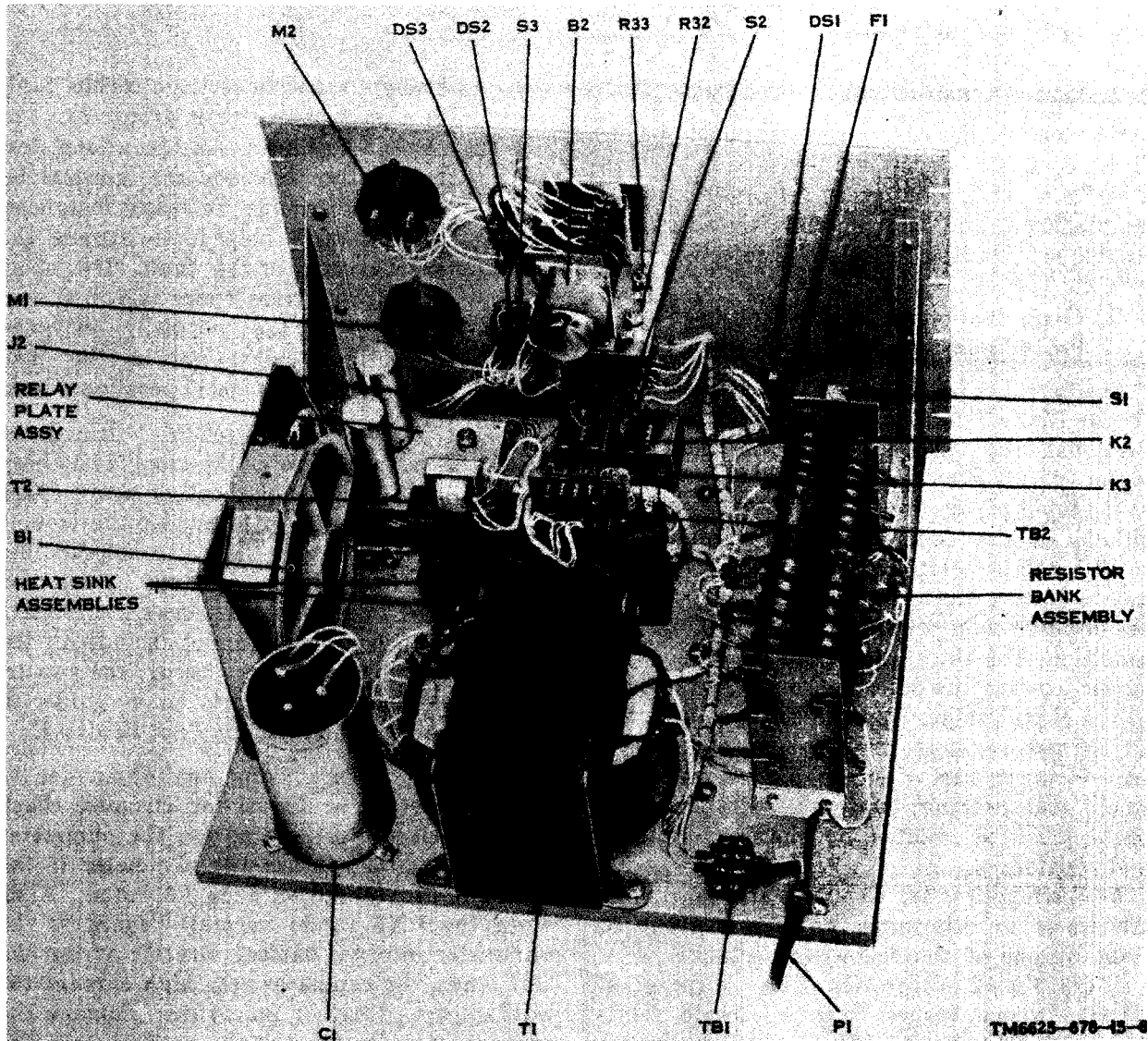

Figure 5-1. Analyzer-Charger Battery AN/ASM-137, parts location, internal view.

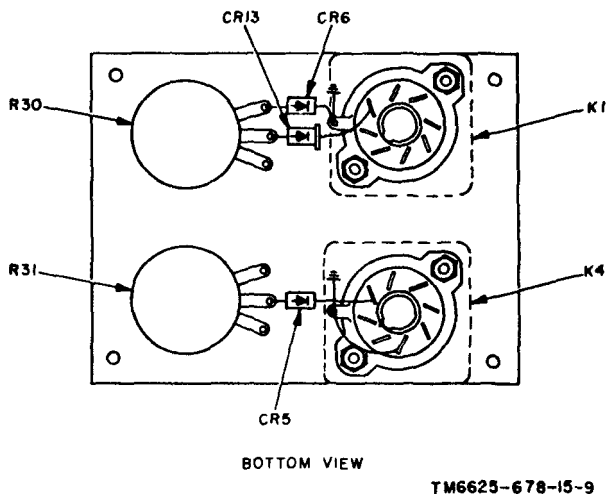

Figure 5-2. Relay plate assembly.

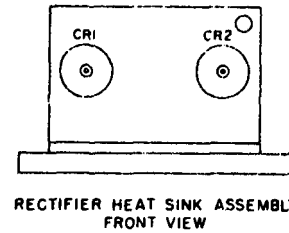
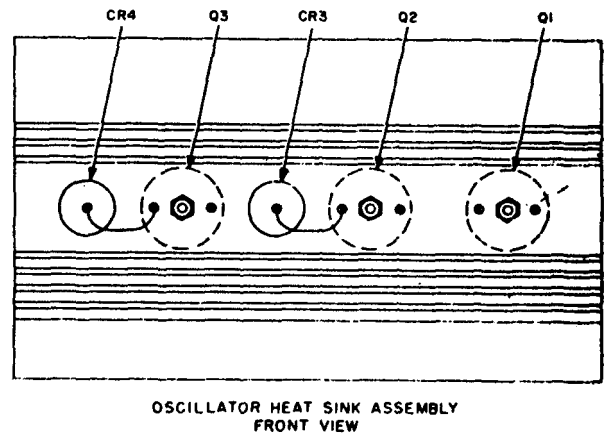

Figure 5-3. Heatsink assemblies.

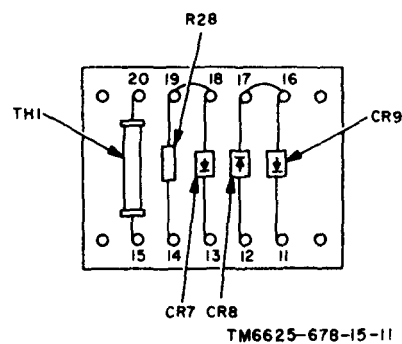
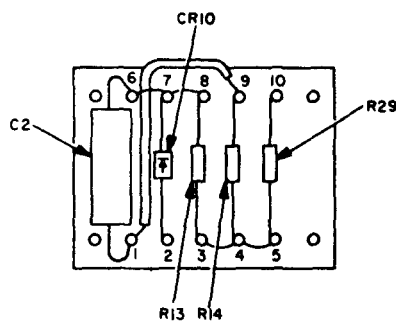

Figure 5-4. Terminal boards TB1 and TB2.

5-3. Test Equipment Required

The chart below lists the test equipment required for troubleshooting the AN/ASM-137. The associated technical manuals are also listed.

Test equipment	Technical manual
Multimeter TS-352B/U	TM 11-6625-366-15
Oscilloscope AN/USM-140B.	TM 11-6625-535-15

Test equipment	Technical manual
Test Set, Transistor TS-1836/U.	TM 11-6625-539-15
Power Supply PP-3940/U.	TM 11-6130-247-15

5-4. Localizing Troubles

a. *General.* In the troubleshooting chart (c below), procedures are outlined for localizing

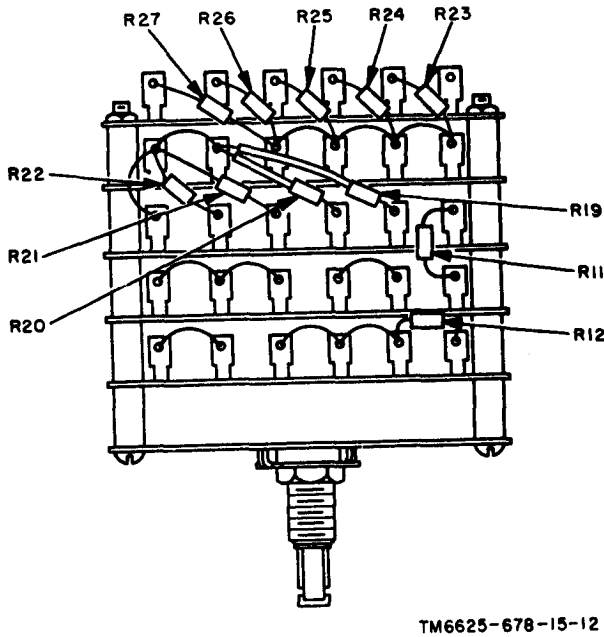

Figure 5-5. SELECTOR switch S2, assembly.

troubles to a stage within the various sections of the AN/ASM-137. Figure 8-3 is the schematic diagram, and figure 8-4 is the wiring diagram. Parts locations are indicated in figures 5-1 through 5-6. Voltage and resistance measurements are shown in figures 5-7 and 5-8. Refer to figure 5-7 for voltage and resistance measurements when the SELECTOR switch is set to MA-5, and to figure 5-8 when the SELECTOR switch is set to MA-7. Figures 5-9 (1) and 5-9 (2) show wave shapes that are useful in troubleshooting. Depending on the nature of the operational symptoms, one or more of the localizing procedures will be necessary. When trouble has been localized to a particular stage, use voltage and resistance measurements to isolate the trouble to a particular park

b. Use of Chart. When an abnormal symptom has been observed in the equipment look for a description of this symptom in the symptom column and perform the corrective measure shown in the *corrective measures* column.

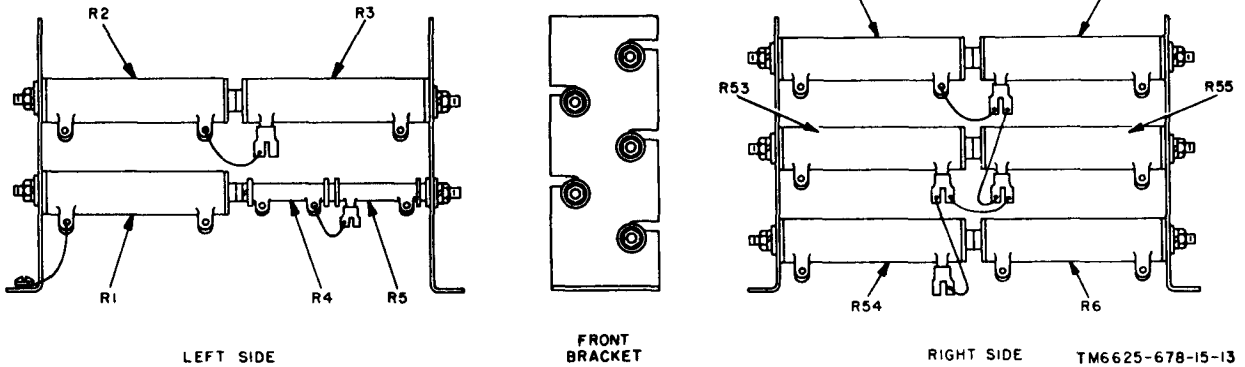

Figure 5-6. Resistor bank assembly.

c. Troubleshooting Chart

Symptom	Probable trouble	Corrective measures
1. AC POWER indicator lamp DS1 does not illuminate when AC POWER ON-OFF switch S1 is set to ON.	Open fuse F1 Lamp DS1 or lamp socket defective. Defective AC POWER ON-OFF switch 1. Defective ac line card or plug. Bad or open connection at terminal board T1.	Replace fuse F1. Replace lamp DS1 or lamp socket. Replace switch S1. Replace ac line cord. Check wire connections at terminal board TB1. Check resistance for continuity between ac plug and pins 1 and 3 of switch S1.

Symptom	Probable trouble	Corrective measures
2. END OF CYCLE indicator lamp DS3 does not extinguish when TIMER switch S4 is set to (S) DISCHARGE.	Defective switch 4 -----	Check switch S4 for clean contacts. Replace S4 if defective.
3. No discharge current indication on ammeter M2.	Loose connection ----- Ammeter M2 defective ----- Discharge contactor D2 defective.	Check connections and repair loose connection. Replace defective ammeter M2. Measure voltages and resistance (fig. 5-7 and 5-8) at the pins of contactor K2.
4. No voltage indication on voltmeter M1.	Loose connection ----- Defective voltmeter M1 -----	Check connections and repair loose connection. Replace defective voltmeter M1.
5. Discharge current is not between 14 and 16 amperes with SELECTOR switch set to MA-5, 10 and 12 amperes with SELECTOR switch set to MA4, or 5 and 6 amperes with SELECTOR switch set to MA-7.	Defective resistor in resistor discharge bank.	Measure resistance of resistors R51, R52, R53, R54, and R55. Replace defective resistor.
6. The 19-volt dropout relay (K1) does not drop out when voltmeter M1 indicator decreases to below 19 volts.	Improper adjustment of variable resistor R30. Defective Zener diode CR13 ----- Relay K1 defective -----	Adjust variable resistor R30, following the procedure given in paragraph 5-7. Replace defective diode CR13. Measure voltages and resistances at the pins of relay K1. Replace defective relay K1.
7. BATTERY LOW indicator lamp DS2 does not light when 19-volt dropout relay K1 releases.	Indicator lamp DS2 or lamp socket defective.	Replace lamp DS2 or lamp socket.
8. No discharge current when the battery terminal voltage is below 19 volts and AUTOMATIC CYCLE-MANUAL DISCHARGE switch S3 is set to MANUAL DISCHARGE.	Defective switch S3 -----	Check switch S3 for clean contacts. Replace defective switch S3.
9. The 19-volt pull-in relay (K4) does not pull in when voltmeter M1 indicator increases to above 19 Volts.	Improper adjustment of variable resistor R31. Relay K4 defective -----	Adjust variable resistor R31, following the procedure given in paragraph 5-7. Measure voltages and resistances at the pins of relay K4. Replace defective relay K4.
10. No main or topping charge current indications on ammeter M2.	Faulty rectifier circuit ----- Faulty passing-regulator circuit.	Check resistance and voltages at positive and negative terminals of capacitor C1. Replace defective component. Check voltages and resistances (fig. 5-7 and 5-8) at transistors Q1, Q2, and Q3. Replace defective component.

Symptom	Probable trouble	Corrective measures
	Faulty triggering circuit -----	Check voltages and resistance (fig. 5-7 and 5-8) at junction of capacitor C2 and diode CR10 and at junction of C2 and resistor R14. Replace defective component.
	Loose connection-----	Check connections and repair loose connection.
	Charge contactor K3 defective.	Measure voltages and resistances at the pins of contactor K3. Replace defective contactor K3.
11. Main charge current is not between 14 and 16 amperes with SELECTOR switch set to MA-5, 10 and 12 amperes with SELECTOR switch set to MA-4, or 4.5 and 6.5 amperes with SELECTOR switch set to MA-7.	Improper adjustment of variable resistor R32.	Adjust variable resistor R32, following the procedure given in paragraph 5-8.
	Defective resistor in high-rate resistor charge bank.	Measure resistance of resistors R19, R20, R21, and R22. Replace defective resistor.
	Faulty passing-regulator circuit.	Measure voltages and resistances at transistors Q1, Q2, and Q3. Check wave shapes across resistors R2 and R3 (fig. 5-9(1) and (2)). Check wave shapes at transistors Q1, Q2, and Q3 (fig. 5-9(1) and (2)). Replace defective component.
12. Charge current flickers and drops toward zero charge current flow, indicating equipment is overheating.	Obstruction of air circulation vents. Fan motor B1 not operating.	Check vents for obstruction. Repair obstruction. Check fan motor for loose connection or physical obstruction. Replace defective fan motor.
	Thermistor TH1 defective -----	Check thermistor TH1 for physical damage. Measure resistance of thermistor TH1 (para 5-5b). Replace defective thermistor.
13. Topping charge current is not between 7 and 8.5 amperes with SELECTOR switch set to MA-5, 4 and 6 amperes with SELECTOR switch set to MA-4, or 1.9 and 2.5 amperes with SELECTOR switch set to MA-7.	Improper adjustment of variable resistor R33.	Adjust variable resistor R33, following the procedure given in paragraph 5-8.
	Defective resistor in low-rate resistor charge bank.	Measure resistance of resistions R23, R24, R25, R26, and R27. Replace defective resistor.
	Faulty passing-regulator circuit.	Check voltages and resistances (fig. 5-7 and 5-8) at transistors Q1, Q2, and Q3. Check wave shapes across resistors R2 and R3. Check wave shapes at transistors Q1, Q2, and Q3 (fig. 5-9(1) and (2)). Replace defective component.

Symptom	Probable trouble	Corrective measure
14. Discharge cycle, main charge cycle, or topping charge cycle does not have a duration of 2 hours \pm 10 minutes.	Defective TIMER switch S4	Check TIMER switch S4. Replace defective TIMER switch S4.
15. END OF CYCLE indicator lamp DS3 does not illuminate at end of cycle.	Lamp DS3 or lamp socket defective.	Replace lamp DS3 or lamp socket.

5-5. Resistance and Voltage Readings

a. Resistance and Voltage Diagrams. The resistance and voltage values shown on figure 5-7 are obtained with SELECTOR switch set to MA-5. The resistance values shown on figure 5-8 are obtained with SELECTOR switch set to MA-7. The resistance and voltage measurements are provided as an aid in troubleshooting and are approximate values.

b. Resistance of Thermistor TH1. Thermistor TH1 is a temperature-sensitive device. The resistance of thermistor TH1 decreases with an increase in temperature. For example, at 25°C., thermistor TH1 is between 18,000 and 22,000 ohms; at 35°C., decreases to between 9,100 and 16,900 ohms; and 50°C., continues to decrease to between 5,600 and 10,400 ohms.

5-6. Waveform Analysis

a. Waveforms may be observed at various points in the circuitry of the AN/ASM-137 with Oscilloscope AN/USM-140B. The normal waveforms obtained are shown in figure 5-9(1) and (2). By the comparison of the observed waveform with the normal waveform, trouble can sometimes be quickly located.

b. Before comparing the waveforms with the normal waveforms, carefully duplicate the conditions under which the normal waveforms were obtained. If an observed waveform does not closely resemble the normal waveform, trouble is indicated.

c. A departure from the normal waveform indicates trouble between the point at which the waveform is observed to be normal and the point at which the waveform is observed to be abnormal; or, it may indicate a defective component in the circuitry immediately preceding

the point at which the waveform was checked. A voltage or resistance check of the stage preceding the test point may isolate the defective component.

5-7. Adjustment of Resistors R30 and R31

Do not connect the ac input power cable and Cable Assembly, Power, Electrical CX-9064/ASM-137 when performing the adjustment procedures given in *a* and *b* below.

a. Adjustment of Resistor R30.

- (1) Connect the negative lead of Power Supply PP-3940/G to chassis ground, and the positive lead to the positive terminal of capacitor C1.
- (2) Unlock and set variable resistor R30 fully counterclockwise (minimum resistance).
- (3) Adjust the PP-3940/G for an output of exactly 19 volts. Relay K1 is energized.
- (4) Adjust variable resistor R30 clockwise until relay K1 deenergizes.
- (5) Lock variable resistor R30 for this setting, set the input power to the PP-3940/G to off, and disconnect the equipment.

b. Adjustment of Resistor R31.

- (1) Set AUTOMATIC CYCLE-MANUAL DISCHARGE switch S3 to MANUAL DISCHARGE.
- (2) Connect the negative lead of Power Supply PP-3940/G to chassis ground, and the positive lead to pin 2 of switch S3-C.
- (3) Unlock and set variable resistor R31 fully clockwise (maximum resistance).

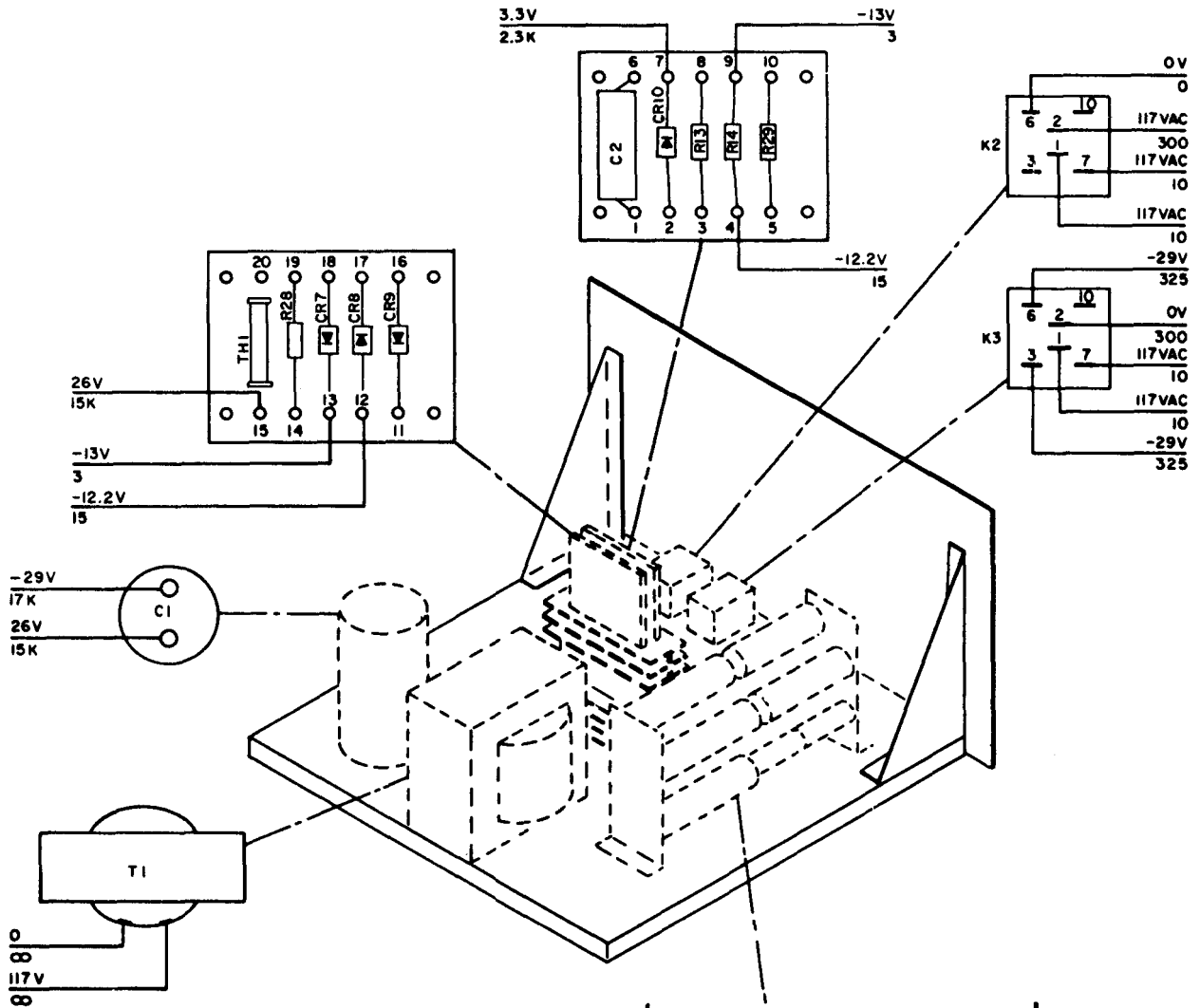

NOTES:

1. LINE VOLTAGE AT 117 VAC.
2. ALL VOLTAGE READINGS ARE TO CHASSIS GROUND AND ARE DC UNLESS OTHERWISE INDICATED.
3. ALL VOLTAGES MEASURED WITH MULTIMETER TS-352B/U OR EQUIVALENT.
4. ALL RESISTANCE READINGS ARE TO CHASSIS GROUND AND ARE IN OHMS UNLESS OTHERWISE INDICATED.
5. ALL RESISTANCES MEASURED WITH MULTIMETER TS-352B/U OR EQUIVALENT, USING THE RANGE WITH RESULTS IN READING AS CLOSE AS POSSIBLE TO MID-SCALE.
6. SWITCHES ARE POSITIONED AS FOLLOWS:
 - a. SELECTOR: MA-5
 - b. AC POWER ON-OFF:
 - ON FOR VOLTAGE MEASUREMENTS.
 - OFF FOR RESISTANCE MEASUREMENTS.
 - c. TIMER: (2) MAIN CHARGE.
 - d. AUTOMATIC CYCLE-MANUAL DISCHARGE:
 - AUTOMATIC CYCLE .

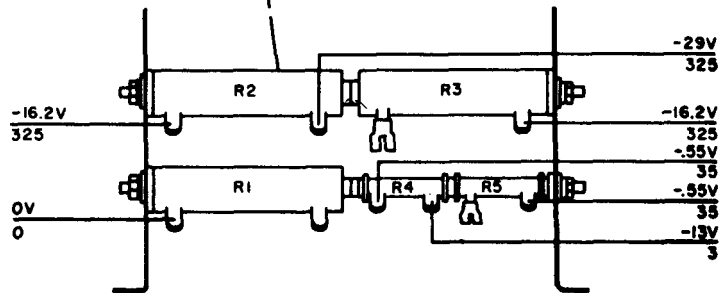

TM6625-678-15-14

Figure 5-7. Resistance and voltage diagram with SELECTOR switch set to MA-5.

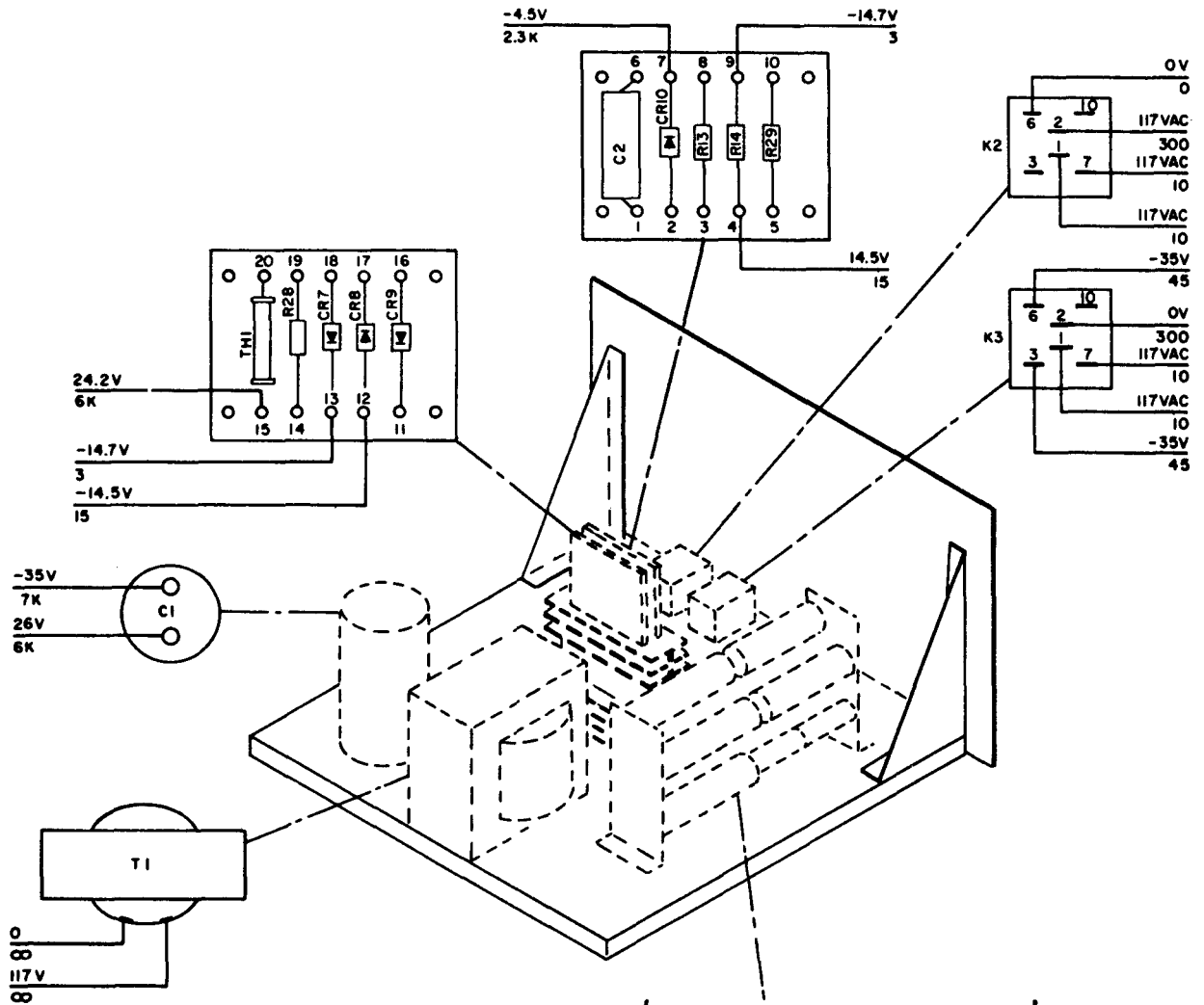

NOTES:

1. LINE VOLTAGE AT 117 VAC.
2. ALL VOLTAGE READINGS ARE TO CHASSIS GROUND AND ARE DC UNLESS OTHERWISE INDICATED.
3. ALL VOLTAGES MEASURED WITH MULTIMETER TS-352B/U OR EQUIVALENT.
4. ALL RESISTANCE READINGS ARE TO CHASSIS GROUND AND ARE IN OHMS UNLESS OTHERWISE INDICATED.
5. ALL RESISTANCES MEASURED WITH MULTIMETER TS-352B/U OR EQUIVALENT, USING THE RANGE WITH RESULTS IN READING AS CLOSE AS POSSIBLE TO MID-SCALE.
6. SWITCHES ARE POSITIONED AS FOLLOWS:
 - a. SELECTOR: MA-7
 - b. AC POWER ON-OFF: ON FOR VOLTAGE MEASUREMENTS. OFF FOR RESISTANCE MEASUREMENTS.
 - c. TIMER: (2) MAIN CHARGE.
 - d. AUTOMATIC CYCLE-MANUAL DISCHARGE: AUTOMATIC CYCLE.

TM6625-678-15-15

Figure 5-8. Resistance and voltage diagram with SELECTOR switch set to MA-7.

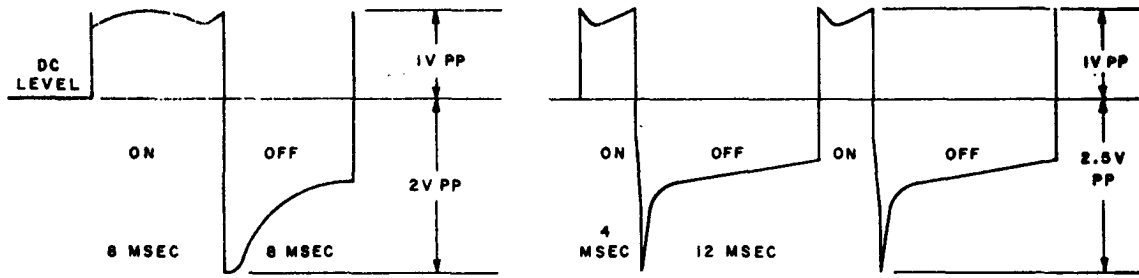

MAIN CHARGE

TOPPING CHARGE

A. EMITTER-TO-BASE WAVESHAPES AT TRANSISTOR Q1.
SELECTOR SWITCH IN MA-5 POSITION.

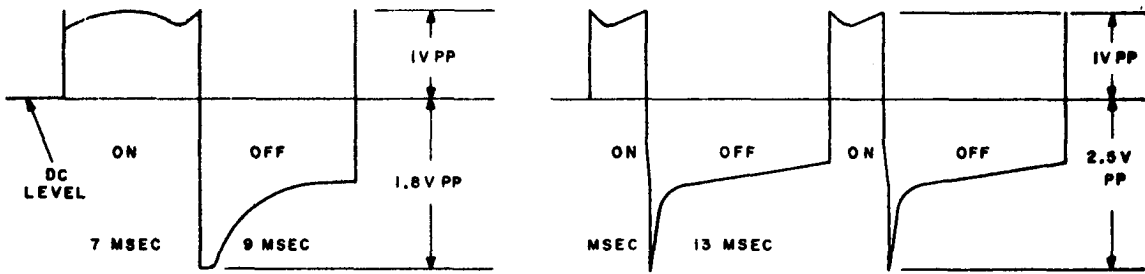

MAIN CHARGE

TOPPING CHARGE

B. EMITTER-TO-BASE WAVESHAPES AT TRANSISTOR Q1.
SELECTOR SWITCH IN MA-7 POSITION.

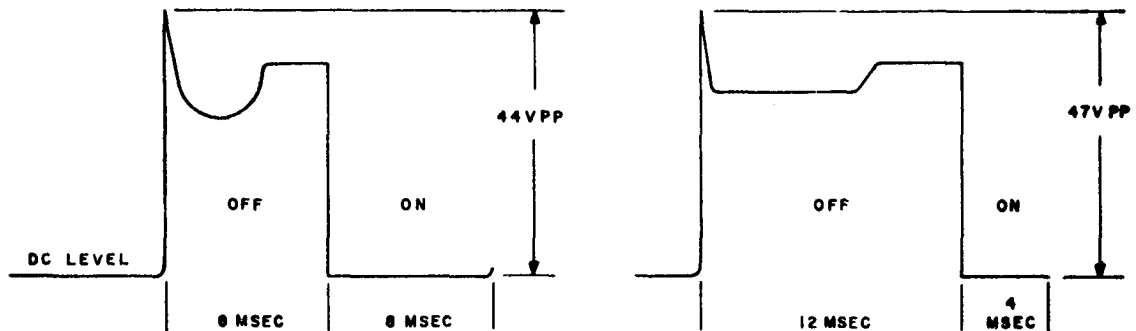

MAIN CHARGE

TOPPING CHARGE

C. COLLECTOR-TO-EMITTER WAVESHAPES AT TRANSISTOR Q1
SELECTOR SWITCH IN MA-5 POSITION

TM6625-678-15-16 ①

Figure 5-9. Waveforms (part 1 of 2).

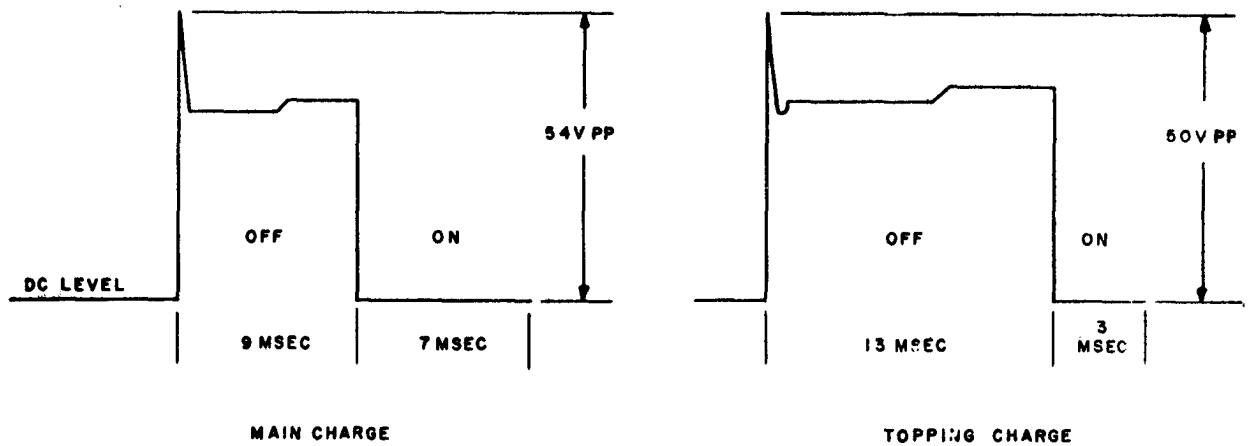

D. COLLECTOR-TO-EMITTER WAVESHAVE AT TRANSISTOR Q1.
SELECTOR SWITCH IN MA-7 POSITION.

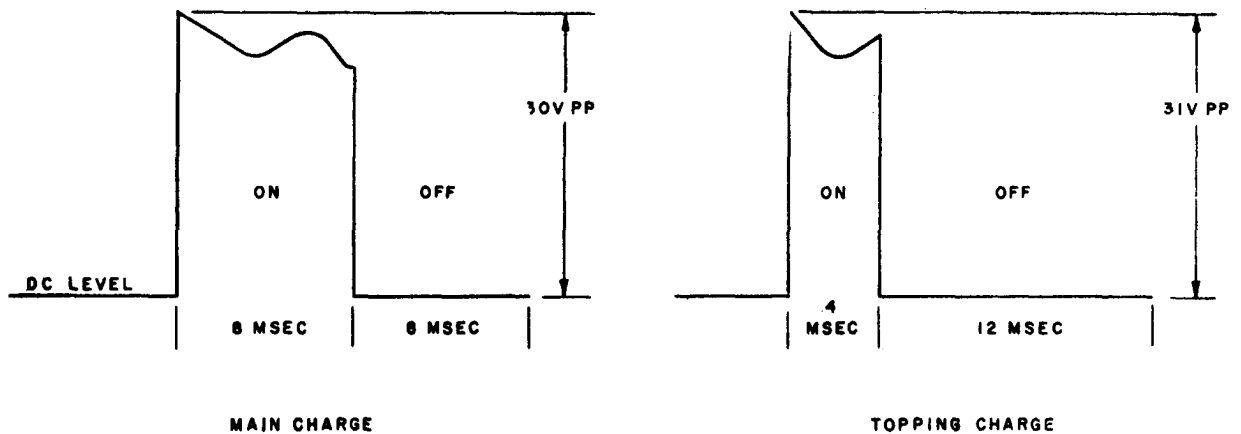

E. CURRENT WAVESHAVE ACROSS R2 OR R3
SELECTOR SWITCH IN MA-5 POSITION.

TM6625-678-15-16 ②

-9-Continued

- (4) Adjust the PP-3940/G for an output of exactly 19 volts.
 - (5) Adjust variable resistor R31 until relay K4 energizes.
 - (6) Lock variable resistor R31 for this setting, set the input power to the PP-3940/G to off and disconnect the equipment.
- 5-8. Adjustment of Resistors R32 and R33
 - a. Set the AC POWER ON-OFF switch to OFF.
 - b. Connect Cable Assembly, Power, Electrical CX-9064/ASM-137 to the BATTERY CABLE connector on the AN/ASM-137 and the terminals of a partly discharged known good Battery, Storage BB-433/A.

c. Connect the ac input power cable from the AN/ASM-137 to the 115-volt, 60-cps power source.

d. Set the SELECTOR switch to MA-5.

e. Set the AUTOMATIC CYCLE-MANUAL DISCHARGE switch to AUTOMATIC CYCLE.

f. Set the AC POWER ON-OFF switch to ON.

g. Set the TIMER switch to (2) MAIN CHARGE and adjust variable resistor R32 for an indication of 16 amperes on AMPERES meter M2.

h. Set the TIMER switch to (4) TOPPING and adjust variable resistor R33 for an indication of 8.5 amperes on AMPERES meter M2.

i. Set the TIMER switch to (6) OFF.

j. Set the AC POWER ON-OFF switch to OFF and disconnect the equipment.

CHAPTER 6

GENERAL SUPPORT TESTING PROCEDURES

6-1. General

a. Testing procedures are prepared for use by Signal Field Maintenance Shops and Signal Service Organizations responsible for general support maintenance of electronic equipment to determine the acceptability of repaired equipment. These procedures set forth specific requirements that repaired equipment must meet before it is returned to the using organization. These procedures may also be used as a guide for testing equipment that has been repaired at direct support category if the proper tools and test equipment are available. A summary of the performance standards is given in paragraph 6-5.

b. Comply with the instructions preceding each chart before proceeding to the chart. Perform each step in sequence. Do not vary the sequence. For each step, perform all the actions required in the *control settings* column; then perform each specific test procedure and verify it against its performance standard.

6-2. Tools and Test Equipment

All test equipment and tools required to perform the testing procedures given in this chapter are listed in *a* and *b* below and are authorized under TA 11-17 (Signal Field Maintenance Shops) and TA 11-100 (11-17) (Allowances of Signal Corps Expendable Supplies for Signal Field Maintenance Shops).

a. Test Equipment.

Nomenclature	Federal stock No.	Technical manual
Multimeter ME-87/U -----	6625-223-5248	None.
Multimeter TS-352B/U -----	6625-563-0142	TM 11-6625-366-15.
Transformer, Variable Power TF-171/USM.	5950-503-0632	None.
Battery, Storage BB-433/A ----	6140-753-2251	TM 11-6140-205-12.

b. Tools. All the tools required are included in Tool Kit, Electronic Equipment TK-100/G.

6-3. Physical Tests and Inspections

- a. *Test Equipment and Material.* None.
- b. *Test Connections and Conditions.*
 - (1) No connections necessary.
 - (2) Remove the top cover by unfastening the captive screw.
- c. *Procedure.*

Step No.	Control settings	Test equipment	Equipment under test	Test procedure	Performance standard
1	None.		Controls may be in any position.	<p>a. Inspect cabinet and chassis for damage, missing parts, and condition of paint.</p> <p><i>Notes.</i> Touchup painting is recommended in lieu of refinishing whenever practical; screwheads, receptacles, and other plated parts will not be painted or polished with abrasives.</p> <p>b. Inspect all controls and mechanical assemblies for loose or missing screws, bolts, and nuts.</p> <p>c. Inspect all connectors, sockets, and receptacles, fuseholder, pilot lights, and meters for looseness, damage, or missing parts.</p>	<p>a. No damage evident or parts missing. External surfaces intended to be painted do not show bare metal. Panel lettering will be legible.</p> <p>b. Screws, bolts, and nuts will be tight. None missing.</p> <p>c. No loose parts or damage. No missing parts.</p>
2	None.		Controls may be in any position.	<p>a. Rotate all panel controls throughout their limits of travel.</p> <p>b. Operate all switches-----</p>	<p>a. Controls will rotate freely without binding or excessive looseness.</p> <p>b. Switches will operate properly.</p>
3	None.		Controls may be in any position.	Manually turn fan blades of motor B1.	Fan blades will turn freely.

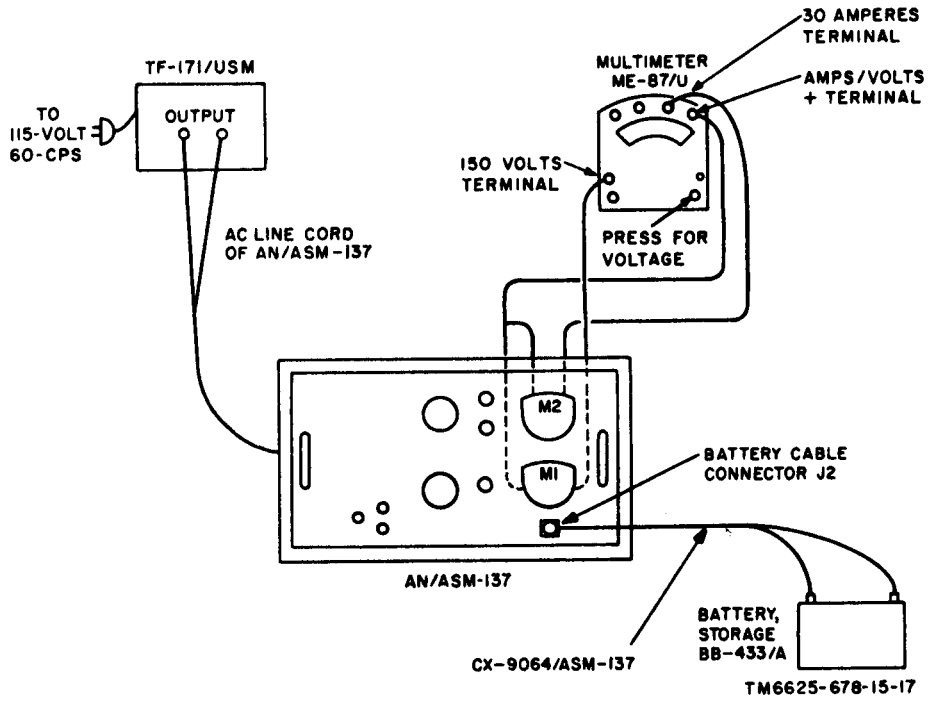

Figure 6-1. Discharge, main charge, and topping charge test connection diagram.

6-5. Test Data Summary

The test data are summarized as follows:

a. VOLTS meter M1 reads within 5 percent of the ME-87/U voltage reading.

b. AMPERES meter M2 reads within 5 percent of the ME-87/U current reading.

c. When discharging a fully charged BB-433/A storage battery in AUTOMATIC CYCLE, discharge currents must be as follows:

- (1) Between 14.5 and 19.5 amperes with SELECTOR switch set to MA-5.
- (2) Between 9.0 and 13.0 amperes with SELECTOR switch set to MA-4.
- (3) Between 4.5 and 6.5 amperes with SELECTOR switch set to MA-7.

d. When charging the BB-433/A in AUTOMATIC CYCLE, during MAIN CHARGE, charge currents must be as follows:

- (1) Between 14 and 16 amperes with SELECTOR switch set to MA-5.
- (2) Between 10 and 12 amperes with SELECTOR switch set to MA-4.
- (3) Between 5 and 6 amperes with SELECTOR switch set to MA-7.

e. When charging the battery in AUTOMATIC CYCLE, during TOPPING, charge currents must be as follows:

- (1) Between 7.5 and 9.5 amperes with SELECTOR switch set to MA-5.
- (2) Between 4 and 5 amperes with SELECTOR switch set to MA-4.
- (3) Between 2 and 3 amperes with SELECTOR switch set to MA-7.

f. BATTERY LOW lamp illuminates when the BB433/A terminal voltage is below 18 volts.

CHAPTER 7

DEPOT OVERHAUL STANDARDS

7-1. Applicability of Depot Overhaul Standards

The tests outlined in this chapter are designed to measure the performance capability of a repair equipment. Equipment that is to be returned to stock should meet the standards given in these tests.

7-2. Applicable References

a. Repair Standards. Applicable procedure of the depots performing these tests and the general standards for repaired electronic equipment given in TB SIG 355-1, TB SIG 355-2, and TB SIG 355-3 form a part of the requirements for testing this equipment.

b. Modification Work Orders. Perform all modification work orders applicable to this equipment before making the tests specified. DA Pam 310-7 lists all available MWO's.

7-3. Test Facilities Required

Nomenclature	Technical manual
Multimeter ME-87/U.	
Multimeter TS-352B/U.	TM 11-6625-366-16
Transformer, Variable Power TF-171/USM.	
Battery, Storage BB-433/A.	TM 11-6140-205-12

7-4. Tests

The depot overhaul standards test procedures are the same as those for general support (para 6-4). Equipment that meets the performance standards stated in these tests will furnish satisfactory operation equivalent to that of new equipment.

CHAPTER 8
SHIPMENT AND LIMITED STORAGE AND DEMOLITION
OF MATERIAL TO PREVENT ENEMY USE

Section I. SHIPMENT AND LIMITED STORAGE

8-1. Disassembly of Equipment

Prepare the AN/ASM-137 for shipment and storage as follows:

a. Disconnect Cable Assembly, Power, Electrical CX-9064/ASM-137 (or CX-9065/ASM-137) from the AN/ASM-137.

b. Remove relays K1 and K4 from their respective sockets.

8-2. Repackaging for Shipment or Limited Storage

The exact procedure for repackaging depends on the material available and the conditions under which the equipment is to be shipped or stored. Adapt the procedures outlined below whenever circumstances permit. The information concerning the original packaging (para 2-1) will also be helpful.

a. Material Requirements. The following materials are required for packaging the AN/ASM-137. For stock numbers of materials, consult SB 38-100.

Material	Quantity
Barrier material, water-proof.	36 sq ft
Tape, cloth backing, waterproof.	15ft
Twine, cotton.....	10 ft

Material	Quantity
Fiberboard, corrugated.	36 sq ft
Tape, gummed paper.	15 ft
Cushioning material (rubberized curled hair) .	32 sq ft

b. Packaging. Package the items of the AN/ASM-137 as outlined below:

(1) *Miscellaneous items.* Wind each cable assembly into a coil and tie with cotton twine. Wrap cable connectors to insure enough protection. Package relays K1 and K4 and running spares to insure enough protection. Place cable assemblies, relays, and running spares into the tray of the AN/ASM-137; use cushioning material to cushion each item as required.

(2) *AN/ASM-137.* Attach the ac line cord to the transformer with cotton twine. Cushion the AN/ASM-137 on all surfaces with pads of cushioning material. Place the cushioned unit within a wrap of corrugated fiberboard. Secure the wrap with gummed tape.

c. Packaging. Pack the consolidated package in a nailed wooden box.

Section II. DEMOLITION OF MATERIEL TO PREVENT ENEMY USE

8-3. Authority for Demolition

The demolition procedures given in paragraph 8-4 will be used to prevent the enemy

from using or salvaging this equipment. Demolition of the equipment will be accomplished only upon the order of the commander.

8-4. Methods of Destruction

The tactical situation and time available will determine the method to be used when destruction of equipment is ordered. In most cases, it is preferable to demolish completely some portions of the equipment rather than partially destroy all the equipment components.

a. Smash. Smash the case, meters, and switches. Smash the internal components.

b. Cut. Cut the wiring of the AN/ASM 137.

Warning: Be extremely careful with explosives and incendiary devices. Use these items only when the need is urgent.

c. Burn. Burn the technical manuals first. Burn as much of the equipment as is flammable.

d. Dispose. Bury or scatter destroyed parts.

COLOR CODE MARKING FOR MILITARY STANDARD RESISTORS

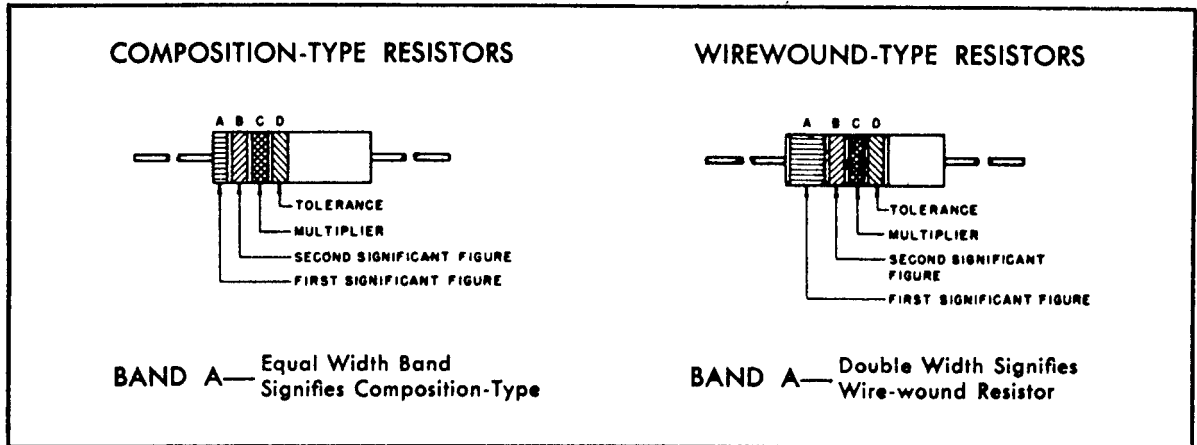

COLOR CODE TABLE

BAND A		BAND B		BAND C		BAND D*	
COLOR	FIRST SIGNIFICANT FIGURE	COLOR	SECOND SIGNIFICANT FIGURE	COLOR	MULTIPLIER	COLOR	RESISTANCE TOLERANCE (PERCENT)
BLACK	0	BLACK	0	BLACK	1		
BROWN	1	BROWN	1	BROWN	10		
RED	2	RED	2	RED	100		
ORANGE	3	ORANGE	3	ORANGE	1,000		
YELLOW	4	YELLOW	4	YELLOW	10,000	SILVER	± 10
GREEN	5	GREEN	5	GREEN	100,000	GOLD	± 5
BLUE	6	BLUE	6	BLUE	1,000,000		
PURPLE (VIOLET)	7	PURPLE (VIOLET)	7				
GRAY	8	GRAY	8	SILVER	0.01		
WHITE	9	WHITE	9	GOLD	0.1		

EXAMPLES OF COLOR CODING

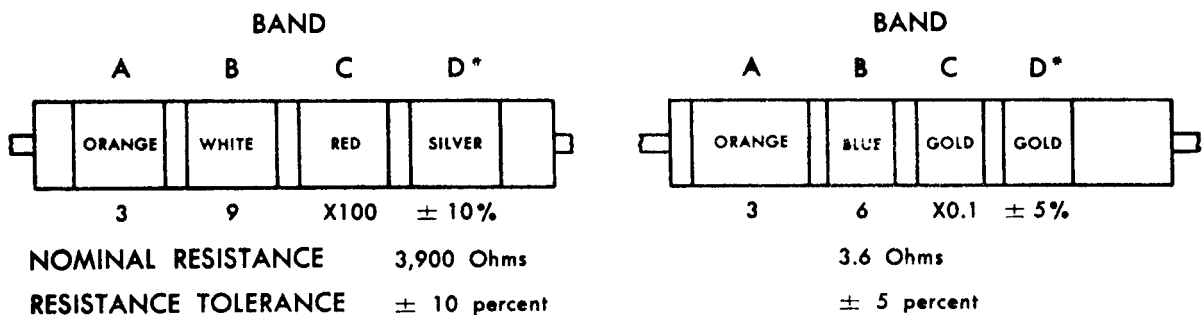

*If Band D is omitted, the resistor tolerance is ± 20%, and the resistor is not Mil-Std.

STD-R2

Figure 8-1. MIL-STD resistor color code markings.

APPENDIX A

REFERENCES

The following is a list of references that should be available to the operator and maintenance personnel of Analyzer-Charger, Battery AN/ASM-137:

DA Pam 310-4	Index of Technical Manuals, Technical Bulletins, Supply Manuals (types 7, 8, and 9), Supply Bulletins, and Lubrication Orders.
DA Pam 310-7	Index of Modification Work Orders.
SB 38-100	Preservation, Packaging and Packing Materials, Supplies and Equipment Used by the Army.
TA 11-17	Signal Field Maintenance Shops.
TA 11-100 (11-17)	Allowances of Signal Corps Expendable Supplies for Signal Field Maintenance Shops.
TB SIG 355-1	Depot Inspection Standard for Repaired Signal Equipment.
TB SIG 355-2	Depot Inspection Standard for Refinishing Repaired Signal Equipment.
TB SIG 355-3	Depot Inspection Standard for Moisture and Fungus Resistant Treatment.
TB SIG 364	Field Instructions for Painting and Preserving Electronics Command Equipment.
TM 9-213	Painting Instructions for Field Use.
TM 11-6130-247-15	Organizational, DS, GS, and Depot Maintenance Manual (Including Repair Parts and Special Tools List). Power Supply PP-3940/G
TM 11-6140-205-12	Operator and Organizational Maintenance Manual: Battery, Storage BB-433/A.
TM 11-6625-366-15	Organizational, DS, GS, and Depot Maintenance Manual: Multimeter TS-352B/U
TM 11-6625-535-15-1	Organizational, DS, GS, and Depot Maintenance Manual: Oscilloscope AN/USM-140B and AN/USM-141A.
TM 11-6625-539-15	Operator, Organizational, Field and Depot Maintenance Manual: Test Sets, Transistor TS-1836/U.
TM 38-750	Army Equipment Record Procedures.

APPENDIX C

MAINTENANCE ALLOCATION

Section I. INTRODUCTION

C-1. General

This appendix provides a summary of the maintenance operations covered in the equipment literature for Analyzer-Charger, Battery AN/ASM-137. It authorizes categories of maintenance for specific maintenance functions on repairable items and components and the tools and equipment required to perform each function. This appendix may be used as an aid in planning maintenance operations.

C-2. Explanation of Format for Maintenance Allocation Chart

a. Group Number. Not used.

b. Component Assembly Nomenclature. This column lists the item names of component units, assemblies, subassemblies, and modules on which maintenance is authorized.

c. Maintenance Function. This column indicates the maintenance category at which performance of the specific maintenance function is authorized. Authorization to perform a function at any category also includes authorization to perform that function at higher categories. The codes used represent the various maintenance categories as follows:

Code	Maintenance category
C----	Operator/Crew
O----	Organizational Maintenance
F----	Field Support Maintenance
H----	General Support Maintenance
D----	Depot Maintenance

d. Tools and Equipment. The numbers appearing in this column refer to specific tools and equipment which are identified by these numbers in section III.

e. Remarks. Self-explanatory.

C-3. Explanation of Format for Tool and Test Equipment Requirements

The columns in the tool and test equipment requirements chart are as follows:

a. Tools and Equipment. The numbers in this column coincide with the numbers used in the tools and equipment column of the MAC. The numbers indicate the applicable tool for the maintenance function.

b. Maintenance Category. The codes in this column indicate the maintenance category normally allocated the facility.

c. Nomenclature. This column lists tools, test, and maintenance equipment required to perform the maintenance functions.

d. Federal stock Number. This column lists the Federal stock number.

e. Tool Number. Not used.

SECTION II. MAINTENANCE ALLOCATION CHART

MAINTENANCE ALLOCATION CHART																		
GROUP NUMBER	COMPONENT ASSEMBLY NOMENCLATURE	MAINTENANCE FUNCTIONS									TOOLS AND EQUIPMENT	REMARKS						
		INSPECT	TEST	SERVICE	ADJUST	ALIGN	CALIBRATE	INSTALL	REPLACE	REPAIR			OVERHAUL	REBUILD				
	ANALYZER-CHARGER BATTERY TS-1963/ASM-137	C		C												10 8 2,3,6,8 1,5,8	Inspects for defects and general appearance Cleans exterior Adjust operational controls Performs operational test Cleans interior Troubleshooting and comprehensive testing Adjust (R30) 19-volt drop-out relay and (R31) 19-volt pull-in relay if required Adjust charging current if required a. R32 Main charge b. R33 Topping charge Test performance after repairing	
	CABLE ASSEMBLY, POWER, ELECTRICAL CX-9064/ASM-137			C												8	Cleans terminals Inspects cable assembly for loose terminals, worn and cracked insulation Test for open and shorts Replace when required Repair as required	
																	1,3,4,5,6,9,10 1,3 thru 10 1,3 thru 10 2,3 7,8	Replaces running spares such as fuses and lamps Repair as required Overhaul for return to supply, maintenance float or user Test performance after repairing Repair as required

MAINTENANCE ALLOCATION CHART

GROUP NUMBER	COMPONENT ASSEMBLY NOMENCLATURE	MAINTENANCE FUNCTIONS										TOOLS AND EQUIPMENT	REMARKS	
		INSPECT	TEST	SERVICE	ADJUST	ALIGN	CALIBRATE	INSTALL	REPLACE	REPAIR	OVERHAUL			REBUILD
	AN/ASM-137 (continued) CABLE ASSEMBLY, POWER, ELECTRICAL CX-9065/ASM-137		0	0					0	F			8 2,3 7,8	Cleans terminals Inspects cable assembly for loose terminals worn and cracked insulation Test for opens and shorts Replace when required Repair as required

SECTION III. TOOL AND TEST EQUIPMENT REQUIREMENTS

TOOL AND TEST EQUIPMENT REQUIREMENTS				
TOOLS AND EQUIPMENT	MAINTENANCE CATEGORY	NOMENCLATURE	FEDERAL STOCK NUMBER	TOOL NUMBER
		AN/ASM-137 (continued)		
1	F,H,D	MULTIMETER ME-87/U	6625-223-5248	
2	O	MULTIMETER AN/URM-105	6625-581-2036	
3	F,H,D	MULTIMETER TS-352B/U	6625-242-5023	
4	F,H,D	OSCILLOSCOPE AN/USM-140B	6625-701-4038	
5	F,H,D	POWER SUPPLY PP-3940/G	6130-985-8136	
6	O,F,H,D	TEST SET, TRANSISTOR TS-1836/U	6625-892-2628	
7	F,H,D	TOOL KIT, ELECTRONIC TK-100/G	5180-605-0079	
8	O,F,H,D	TOOL KIT, ELECTRONIC TK-105/G	5180-610-8177	
9	F,H,D	TRANSFORMER, VARIABLE POWER TF-171/USM	5950-503-0632	
10	C,O,F,H,D	BATTERY STORAGE BB-433/A	6140-753-2251	

APPENDIX D

ORGANIZATIONAL, DS, GS, AND DEPOT REPAIR PARTS

Section I. INTRODUCTION

D-1. Scope

This appendix contains a list of repair parts required for the performance of organizational maintenance and a list covering the corresponding requirements for direct support, general support, and depot maintenance for Analyzer-Charger Battery AN/ASM-137.

Note. No special tools, test, and support equipment are required.

D-2. General

The repair parts listed are divided into the following sections.

a. Repair Parts for Organizational Maintenance, Section II. Repair parts authorized for direct support, general support, and depot maintenance are included in this section.

b. Repair Parts for Direct Support, General Support, and Depot Maintenance, Section III. Repair parts authorized for direct support, general support, and depot maintenance are included in this section.

Note. All indexes noted below are cross referenced to index numbers. The index number appears in ascending sequence in column 1 of the repair parts list (para D-3a). The index number for the particular item will be the same for the item in all sections of this appendix.

c. Federal Stock Number Cross-Reference to Index Numbers, Section IV. This is a cross-reference index of Federal stock numbers and manufacturer's part numbers to index numbers.

d. Figure and Item Number Cross-Reference to Index Number, Section V. This is a cross-reference index of figure number and item number (or reference designation) to index number. The figure numbers are listed in numerical sequence; item num-

bers and/or reference designations are listed for each figure.

e. Reference Designation Cross-Reference to Index Number, Section VI. This is a cross-reference index of reference and/or item numbers to index numbers.

D-3. Explanation of columns

An explanation of the columns is given below.

a. Source, Maintenance, and Recoverability Codes (SMR), and Index Number Column. The first line in this column lists the applicable SMR codes for the part. Listed in ascending order directly below the SMR codes is the index number assigned to the repair part.

- (1) *Source code (S).* The selection status and source for the listed item is noted here. Source code and its explanation is as follows:

Code	Explanation
P -	applies to repair parts that are stocked in or supplied from the GSA/DSA, or Army supply system, and authorized for use at indicated maintenance categories.

- (2) *Maintenance code (M).* The lowest category of maintenance authorized to install the item is listed here.

Code	Explanation
O	Organizational Maintenance
F	Direct Support Maintenance

- (3) *Recoverability code (R).* Not used.

Note. When no code is indicated in the recoverability column, the part will be considered expendable.

b. Federal Stock Number Column. The Federal stock number for the item is listed in this column.

c. Description Column. This column includes the Federal item name and any additional description of the item required, the manufacturer's part number (reference number), and the applicable five-digit Federal Supply Code for Manufacturers (para D-5). Usable on code column is not used.

d. Unit of Issue Column. The unit used as a basis of issue (e.g. ea, pr, ft, yd, etc.) is indicated in this column.

e. Quantity Incorporated in Unit Pack Column. Not used.

f. Quantity Incorporated in Unit Column. The quantity of repair parts in an assembly is given in this column.

g. Maintenance Allowance Column.

- (1) The maintenance allowance columns are divided into subcolumns. Items authorized for use as required, but not for initial stockage, are identified with an asterisk (*) in the allowance column.
- (2) Subsequent changes to organizational allowances will be limited as follows: No change in the range of items is authorized. If additional items are considered necessary, recommendation should be forwarded to Commanding General, U.S. Army Electronics Command, ATTN: AMSEL-ME-NMP-TB Fort Monmouth, N.J. 07703, for exception or revision to the allowance list. Revisions to the range of items authorized will be made by the USA ECOM National Maintenance Point based upon engineering experience, demand data, or TAERS information.
- (3) The quantitative allowances for DS/GS categories of maintenance will represent initial stockage for a 30-day period for the number of equipments supported.

h. One-Year Allowances Per 100 Equipments/Contingency Planning Purposes Column. This column indicates the total quantity required for distribution and contingency planning purposes. The range of items indicates total quantities of all authorized items required to provide for adequate support of 100 equipments for 1 year.

i. Depot Maintenance Allowance Per 100 Equipments Column. This column indicates the total quantity of each item authorized depot maintenance for 100 equipments.

j. Illustrations Column.

- (1) *Figure number (a).* The number of the illustration in which the item is shown is indicated in this column.
- (2) *Item No. or reference designation (b).* The callout number or reference designation used to reference the item in the illustration appears in this column.

D-4. Location of Repair Parts

a. This manual contains three cross-reference indexes (sect. IV, V, and VI), to be used to locate a repair part when either the Federal stock number, reference number (manufacturer's part number), figure number, or reference designation is known. The first column in each cross-reference index is prepared, as applicable, in numerical or alphanumerical sequence. The last column of each cross-reference index lists the index number assigned to the part.

b. Refer to the appropriate cross-reference index (para D-2c,d,e) and note the index number in the last column; then refer to the repair parts list to locate the index number which is listed in ascending order in column 1 of the repair parts list.

D-5. Federal Supply Codes

This paragraph lists the Federal supply code and the associated manufacturer's name.

<i>Code Number</i>	<i>Manufacturer's name</i>
01537.....	Motorola Communications and Electronics, Inc.
02660.....	Amphenol Corp.
08644.....	Briggs Manufacturing Co.
40931.....	Honeywell, Inc.
55933.....	Sonotone Corp.
66640.....	Wright Aeronautical, Division of Curtiss-Wright Corp.
70611.....	Ark-Les Switch Corp.
71279.....	Cambridge Thermionic Corp.
71400.....	Bussmann Mfg., Division of McGraw-Edison Co.
72354.....	John E. Fast Co., Division of Victoreen Instrument Co., Inc.
72619.....	Dialight Corp.
72699.....	General Instrument Corp.
73096.....	The Hart Mfg. Co.
75915.....	Littlefuse, Inc.
76385.....	Minor Rubber Co., Inc.
80063.....	Army Electronics Command
80211.....	Motorola, Inc.
80992.....	Generals Metals Corp.
81672.....	General Automatic Products Corp.
82877.....	Rotron Mfg. Co., Inc.
83186.....	Victory Engineering Corp.
88140.....	Cutler-Hammer, Inc.
93978.....	N. G. Slater Corp.
97979.....	Reon Resistor Corp.

SECTION II. REPAIR PARTS FOR ORGANIZATIONAL MAINTENANCE

(1) SMR CODE INDEX NO.	(2) FEDERAL STOCK NUMBER	(3) DESCRIPTION Reference Number & Mfr Code USABLE ON CODE	(4) UNIT OF ISSUE	(5) QTY INC IN UNIT PACK	(6) QTY INC IN UNIT	(7) 15-DAY ORGANIZATIONAL MAINTENANCE-ALW				(8) ILLUSTRATIONS		
						(a) 1-5	(b) 6-20	(c) 21-50	(d) 51-100	(a) FIG NO.	(b) ITEM NO. OR REFERENCE DESIGNATION	
AO01	6625-759-2882	ANALYZER-CHARGER, BATTERY AN/ASM-137: Metallic rectifier type; 30 v charging; 15 amp, continuous charging; oper power req; 115 vac; 60 cps, 1 ph; closed metal case; 21-1/2 in lg X 18 in w X 14-1/2 in h; type PCA-131; 55933 (This item is nonexpendable)										
P-O AO09	5920-284-8879	FUSE, CARTRIDGE: 12 amp; 250 v max; 0.250 in dia X 1.250 in lg; p/n 3AB-12; 75915	ea		1	*	*	*	*			
P-O AO14	6240-682-3411	LAMP, CAESTUM VAPOR: 105 to 125 vac; 1/3 w; Bayonet type; bulb T-3-1/4; 1-1/8 in max lg; p/n NE-51H; 72619	ea		3	*	*	*	*			
P-O AO16	6210-944-4620	LIGHT, PANEL: Elect rating, 105-125 vac; 1/3 w; bulb T-3-1/4; 2.187 in lg X 1.000 in dia; yellow; p/n 52463-993-311; 72619	ea		1	*	*	*	*			
P-O AO17	6210-944-4621	LIGHT, PANEL: Elect rating, 105-125 vac; 1/3 w; bulb T-3-1/4; 2.187 in lg X 1.000 in dia; Red; p/n 52463-991-311; 72619	ea		2	*	*	*	*			

SECTION III. REPAIR PARTS FOR DIRECT SUPPORT, GENERAL SUPPORT, AND DEPOT MAINTENANCE

(1) S/R CODE	(2) FEDERAL STOCK NUMBER	(3) DESCRIPTION USABLE ON CODE	(4) UNIT OF MEAS	(5) QTY INC IN UNIT	(6) 30-DAY DS MAINT ALLOWANCE			(7) 30-DAY GS MAINT ALLOWANCE			(8) 1 YR ALW PER EQUIP CNTGCT	(9) DEPOT MAINT ALW PER 100 EQUIP	(10) ILLUSTRATIONS	
					(a) 1-20	(b) 21-50	(c) 51-100	(a) 1-20	(b) 21-50	(c) 51-100			(a) FIG NO.	(b) ITEM NO. OR REFERENCE DESIGNATION
A001	6625-759-2882	ANALYZER-CHARGER, BATTERY AN/ASM-137: Metallic rectifier type; 30 v charging; 15 amp, continuous charging oper power req; 115 vac; 60 cps, 1 ph; closed metal case; 21-1/2 in lg X 18 in w X 14-1/2 in h; type PCA-131; 55933 (This item is nonexpendable)											1-1	
P-F A002	6625-006-7687	AMMETER: Panel type; 1.019 in d meter to mtg flange; 2.720 in w; 2.720 in h; 2.160 in dia meter body; Meter Mod Instr p/n MMI-8445	ea	1	*	*	*	*	*	*	2	5	5-1	M2
P-F A003	5910-829-0249	CAPACITOR, FIXED, PLASTIC: 1 sect; 100 vdc; cap data 470,000 pf, style No. 25.k, RDG1; .47 mf; 8PM183K; 72354	ea	1	*	*	*	*	*	*	2	5	5-4	C2
P-F A004	5340-535-6468	CLAMP LOOP: Steel; 0.375 in w; 0.032 in thk, 0.560 in loop center to nearest mtg hole center; 0.313 in id loop; 0.748 in loop center to end of tongue; 0.204 in dia hole; p/n MS-21919G-5; 80992	ea	1	*	*	*	*	*	*	1	4		
P-F A005	6130-944-0090	COMPONENT BOARD ASSEMBLY: Plastic; 2-5/8 in lg X 2 in w X 3/4 in thk; p/n 27012; 55933	ea	1	*	*	*	*	*	*	1	4	5-1	TB-2
P-F A006	6130-944-0091	COMPONENT BOARD ASSEMBLY: Plastic; 2-5/8 in lg X 2 in w X 3/4 in thk; p/n 27013; 55933	ea	1	*	*	*	*	*	*	1	4	5-1	TB-3
P-F A007	5935-853-3375	CONNECTOR, RECEPTACLE, ELECTRICAL: 5 contacts: 1 connector mating end; 1-37/64 in lg; 1-1/16 in dia; locking type; p/n M33106A-22-12S; 02660	ea	1	*	*	*	*	*	*	1	4		J2
P-F A008	5340-919-9400	FAN, TUBE AXIAL: Fixed-unit; propeller, 1 stage, 6.500 in od, 3 blades; plastic; p/n 16410; 82877	ea	1	*	*	*	*	*	*	1	4	5-1	B1
P-O A009	5920-264-8879	FUSE, CARTRIDGE: 12 amp; 250 v max; 0.250 in dia X 1.250 in lg; p/n 3AB-12; 75915	ea	1	*	*	*	*	*	2	5	12		F1
P-F A010	5920-952-6451	FUSEHOLDER: 1.250 in lg; 0.250 in dia; 250 v; 15 amp; 2.282 in lg; 0.687 in dia; terminals 2; one 1/2 in dia mtg hole; p/n HKP-CC; 71400	ea	1	*	*	*	*	*	*	1	4		XF1
P-F A011	5325-944-4733	GROMMET, RUBBER: Synthetic rubber; 1.500 in od large flange; 1.250 in od groove; 0.125 in thk flange; 1.000 in dia hole; 0.312 in h; 0.062 in w groove; o/a; p/n Z-340; 76385	ea	1	*	*	*	*	*	*	1	4		
P-F A012	6130-947-2871	HEAT, SINK, ASSEMBLY: 7 in lg X 4 in w X 1-1/2 in thk; p/n 27009; 55933	ea	1	*	*	*	*	*	*	1	4	5-1	
P-F A013	5940-549-9573	INSULATOR, STAND-OFF: 0.250 in; 0.187 in; 0.125 in; 0.312 in; o/a; p/n X-2045-X; 71279	ea	1	*	*	*	*	*	*	1	4		
P-O A014	6240-682-3411	LAMP, CAESTUM VAPOR: 105 to 125 vac; 1/3 w; Bayonet type; bulb T-3-1/4; 1-1/8 in max lg; p/n NE-51H; 72619	ea	3	*	*	*	*	2	2	9	18	5-1	DS1, DS2, DS3
P-F A015	6130-943-7368	LEAD AND CONDUIT ASSEMBLY, ELECTRICAL: P/n 27045-7; 55933	ea	1	*	*	*	*	*	*	2	5		
P-O A016	6210-944-4620	LIGHT, PANEL: Elect rating, 105-125 vac; 1/3 w; bulb T-3-1/4; 2.187 in lg X 1.000 in dia; yellow; p/n 52463-993-311; 72619	ea	1	*	*	*	*	*	*	2	5		
P-O A017	6210-944-4621	LIGHT, PANEL: Elect rating, 105-125 vac; 1/3 w; bulb T-3-1/4; 2.187 in lg X 1.000 in dia; red; p/n 52463-991-311; 72619	ea	2	*	*	*	*	*	*	4	10		

SECTION III. REPAIR PARTS FOR DIRECT SUPPORT, GENERAL SUPPORT AND DEPOT MAINTENANCE (CONTINUED)

(1) SMP CODE	(2) FEDERAL STOCK NUMBER	(3) DESCRIPTION REFERENCE NUMBER & MFR. CODE	(4) UNIT OF MEAS	(5) QTY INC IN UNIT	(6) 30-DAY DS MAINT ALLOWANCE			(7) 30-DAY GS MAINT ALLOWANCE			(8) 1 YR ALW PER EQUIP CNTGCTY	(9) DEPOT MAINT ALW PER 100 EQUIP	(10) ILLUSTRATIONS	
					(a) 1-20	(b) 21-50	(c) 51-100	(a) 1-20	(b) 21-50	(c) 51-100			(a) FIG NO.	(b) ITEM NO. OR REFERENCE DESIGNATION
P-F A018	5945-944-4756	RELAY, ARMATURE: Dpdt; 28 v dc; max rated voltage; 2-1/16 in lg X 1-9/16 in w X 2-3/8 in h; p/n 21041; 81672	ea	2	*	*	*	*	*	*	4	10	5-2	K1, K4
P-F A019	5945-944-4757	RELAY, ARMATURE: Dpdt; 120 vac; max rated voltage; 2-1/16 in lg X 1-9/16 in w X 2-3/8 in h; p/n WU-115A2-115; 73096	ea	2	*	*	*	*	*	*	4	10	5-1	K2, K3
P-F A020	5905-252-4018	RESISTOR: P/n 27052-2; 55933	ea	2	*	*	*	*	*	*	2	5	5-6	R6
P-F A021		RESISTOR, FIXED, COMPOSITION: MIL-R-11A, type No. RC20GF470J; p/n 27056-1; 55933	ea	1	*	*	*	*	*	*	2	5	5-5	R20
P-F A022	5905-889-7884	RESISTOR, FIXED, COMPOSITION: MIL-R-11/3 type No. RC20GF3ROJ; p/n 27056-2; 55933	ea	1	*	*	*	*	*	*	2	5	5-5	R21
P-F A023	5905-279-3521	RESISTOR, FIXED, COMPOSITION: MIL-R-11 type No. RC20GF150J; p/n 27056-3; 55933	ea	1	*	*	*	*	*	*	2	5	5-5	R22
P-F A024	5905-256-0415	RESISTOR, FIXED, COMPOSITION: MIL-R-11 type No. RC20GF161J; p/n 27056-4; 55933	ea	1	*	*	*	*	*	*	2	5	5-5	R23
P-F A025	5905-279-1894	RESISTOR, FIXED, COMPOSITION: MIL-R-11 type No. RC20GF820J; p/n 27056-5; 55933	ea	1	*	*	*	*	*	*	2	5	5-5	R24
P-F A026	5905-279-3517	RESISTOR, FIXED, COMPOSITION: MIL-R-11 type No. RC20GF510J; p/n 27056-6; 55933	ea	1	*	*	*	*	*	*	2	5	5-5	R25
P-F A027	5905-279-3516	RESISTOR, FIXED, COMPOSITION: MIL-R-11 type No. RC20GF910J; p/n 27056-8; 55933	ea	1	*	*	*	*	*	*	2	5	5-5	R26
P-F A028	5905-185-8510	RESISTOR, FIXED, COMPOSITION: MIL-R-11A type No. RC20GF103J; p/n 22951-10; 55933	ea	1	*	*	*	*	*	*	2	5	5-5	R12
P-F A029	5905-195-6806	RESISTOR, FIXED, COMPOSITION: MIL-R-11A type No. RC20GF102J; p/n 22951-11; 55933	ea	1	*	*	*	*	*	*	2	5	5-5	R11
P-F A030	5905-279-1879	RESISTOR, FIXED, COMPOSITION: MIL-R-11 type No. RC20GF270J; p/n 22951-16; 55933	ea	1	*	*	*	*	*	*	2	5	5-5	R27
P-F A031	5905-190-8889	RESISTOR, FIXED, COMPOSITION: MIL-R-11 type No. RC20GF101J; p/n 22951-18; 55933	ea	1	*	*	*	*	*	*	2	5	5-5	R19
P-F A032	5905-946-1123	RESISTOR, ASSEMBLY: p/n 27019 55933	ea	1	*	*	*	*	*	*	2	5	5-6	R1, R4, R5
P-F A033	5905-946-1124	RESISTOR, ASSEMBLY: p/n 27022; 55933	ea	1	*	*	*	*	*	*	2	5	5-6	R6, R54
P-F A034	5905-946-1125	RESISTOR, ASSEMBLY: p/n 27020; 55933	ea	1	*	*	*	*	*	*	2	5	5-6	R51, R52
P-F A035	5905-946-1141	RESISTOR, ASSEMBLY: p/n 27021; 55933	ea	1	*	*	*	*	*	*	2	5	5-6	R53, R55
P-F A036	5905-948-3168	RESISTOR, ASSEMBLY: 2 resistors; fixed ribbon-wound type; 9-1/4 in thd rod, #10-32 NF2B thd; p/n 27018; 55933	ea	1	*	*	*	*	*	*	2	5	5-6	R2, R3
P-F A037	5905-880-8423	RESISTOR, THERMAL: p/n 42R5; 83186	ea	1	*	*	*	*	*	*	2	5	5-4	TH1
P-F A038	5905-926-2818	RESISTOR, VARIABLE: 1 sect; 2 k ohms; 10 pct; 2 w non-power rating; p/n HV4LAYS202A; 97979	ea	2	*	*	*	*	*	*	4	10	5-2	R30, R31
P-F A039	5905-926-2819	RESISTOR, VARIABLE: 25 ohms; 10 pct; 2 w non-power rating; p/n RV4LAYS250B; 97979	ea	2	*	*	*	*	*	*	4	10	5-1	R32, R33

SECTION III. REPAIR PARTS FOR DIRECT SUPPORT, GENERAL SUPPORT, AND DEPOT MAINTENANCE (CONTINUED)

(1) SIR CODE	(2) FEDERAL STOCK NUMBER	(3) DESCRIPTION	(4) UNIT OF ISSUE	(5) QTY INC IN UNIT PACK	(6) QTY INC IN UNIT	(7) 30-DAY DS MAINT ALLOWANCE			(8) 30-DAY GS MAINT ALLOWANCE			(9) 1 YR ALW PER EQUIP CMTG CY	(10) DEPOT MAINT ALW PER 100 EQUIP	(11) ILLUSTRATIONS	
						(a) 1-20	(b) 21-50	(c) 51-100	(a) 1-20	(b) 21-50	(c) 51-100			(a) FIG NO.	(b) ITEM NO. OR REFERENCE DESIGNATION
P-F AO40	5910-944-4714	RETAINER, CAPACITOR: Metallic; 1.750 in radius centerline, retainer to centerline mtg holes; 120 deg between mtg holes 3,000 in dia, 1.125 in h; mounting holes two 0.187 in dia; p/n 362-7; 72699	ea		1	*	*	*	*	*	*	2	5		
P-F AO41	5960-557-6122	SEMICONDUCTOR DEVICE, DIODE: P/n SLA13 (1N536); 93978	ea		5	*	*	*	*	*	*	4	10	5-2 5-4	CR5 CR7 thru CR10
P-F AO42	5960-826-9048	SEMICONDUCTOR DEVICE, DIODE: MILL-S-19500 type No. 1N3020A; 80063	ea		1	*	*	*	*	*	*	2	5	5-2	CR13
P-F AO43	5935-848-8903	SOCKET, ELECTRON TUBE: Mounting dim two holes; 0.125 in dia; spaced 1-1/2 in c to c; p/n 168-001; 66640	ea		2	*	*	*	*	*	*	4	10		
P-F AO44	5930-946-4990	SWITCH, ROTARY: 6 amp; 25 volts; 5-1/2 in lg X 3 in w X 2-1/4 in thk; p/n 27029; 55933	ea		1	*	*	*	*	*	*	2	5	5-1	S2
P-F AO45	5930-240-3690	SWITCH, TOGGLE: 10 amp, 250 v; 3 pdt; p/n 7615X2; 88140	ea		1	*	*	*	*	*	*	2	5	5-1	S3
P-F AO46	5930-655-1575	SWITCH, TOGGLE: Dpst; 1.346 in lg X 0.750 in w X 1.125 in h; elect ratings per MS35059; MS35059-22; 80063	ep		1	*	*	*	*	*	*	2	5	5-1	S1
P-F AO47	5940-926-0084	TERMINAL LUG: Solderless connection; w/clamping ears, 0.067 in w; 0.815 in lg, 0.300 in w o/a; p/n 42599-2; 02660	ea		10	*	2	2	*	2	2	10	19		
P-F AO48	5940-926-0085	TERMINAL LUG: Solderless connection; w/clamping ears, 0.062 in w; 0.815 in lg, 0.300 in w o/a; p/n 42332-2; 02660	ea		16	*	2	2	*	2	2	15	27		
P-F AO49	5940-944-2429	TERMINAL, LUG: 7/8 in lg, 9/16 in w o/a; 0.300 in thk mtg portion; p/n 3000841B; 70611	ea		6	*	*	2	*	*	2	6	13		
P-F AO50	6645-926-4394	TIMER, STOP: Electrical type; 115 vac; 60 cyc; 2 in h X 2-7/8 in w X 5 in d; p/n 31; 08644	ea		1	*	*	*	*	*	*	2	4	5-1	B2
P-F AO51	5950-999-4165	TRANSFORMER, POWER, STEP-DOWN: Primary winding input; 117 v 50 to 60 cps; 1 ph; secondary winding, 96 v, center tapped at 15 v, 45 v and 117 v; 5-312 in h X 6,500 in lg X 6.375 in w; p/n 27007; 55933	ea		1	*	*	*	*	*	*	2	5	5-1	T1
P-F AO52	5950-944-4748	TRANSFORMER, PULSE: 2.000 in h X 2.2500 in lg X 1.000 in w; terminals 4; p/n 27051; 55933	ea		1	*	*	*	*	*	*	2	5	5-1	T2
P-F AO53	5960-649-9371	TRANSISTOR: P/n 2M1100; 01537	ea		2	*	*	*	*	*	*	2	5	5-3	Q2, Q3
P-F AO54	5961-944-4749	TRANSISTOR: Terminals 2; Solder lug; 1 stud type; 1.220 in dia X 1.070 in o/a; p/n 2M2153; 80211	ea		1	*	*	*	*	*	*	2	5	5-3	Q1
P-F AO55	6625-930-3826	VOLTMETER: Panel type; 0 to 40 cw range; 1.010 depth of meter to mtg flange; 2.720 in width of meter; 2.720 in height of meter; 2.160 in dia meter body; p/n 106041-0122; 40931	ea		1	*	*	*	*	*	*	2	5	5-1	M1

SECTION IV. INDEX-FEDERAL STOCK NUMBER CROSS REFERENCE
TO INDEX NUMBER (CONTINUED)

FEDERAL STOCK NUMBER	INDEX NO.	FEDERAL STOCK NUMBER	INDEX NO.	FEDERAL STOCK NUMBER	INDEX NO.
5325-944-4733	A011	5940-944-2429	A049		
5340-535-6468	A004	5945-944-4756	A018		
5340-919-9400	A008	5945-944-4757	A019		
5905-185-8510	A028	5950-944-4748	A052		
5905-190-8889	A031	5950-999-4165	A051		
5905-195-6806	A029	5960-557-6122	A041		
5905-252-4018	A021	5960-649-9371	A053		
5905-256-0415	A024	5960-826-9048	A042		
5905-279-1879	A030	5961-944-4749	A054		
5905-279-1894	A025	6130-943-7368	A015		
5905-279-3516	A027	6130-944-0090	A005		
5905-279-3517	A026	6130-944-0091	A006		
5905-279-3521	A023	6130-947-2871	A012		
5905-880-8423	A037	6210-944-4620	A016		
5905-889-7884	A022	6210-944-4621	A017		
5905-926-2818	A038	6240-682-3411	A014		
5905-926-2819	A039	6625-759-2882	A001		
5905-946-1123	A032	6625-930-3826	A055		
5905-946-1124	A033	6645-926-4394	A050		
5905-946-1125	A034	REFERENCE	INDEX		
5905-946-1141	A035	<u>NUMBER</u>	<u>NO</u>		
5905-948-3168	A036	27052-2	A020		
5910-829-0249	A003				
5910-944-4714	A040				
5910-944-4719	A002				
5920-284-8879	A009				
5920-952-6451	A010				
5930-240-3690	A045				
5930-655-1575	A046				
5930-946-4990	A044				
5935-848-8903	A043				
5935-853-3375	A007				
5940-549-9573	A013				
5940-926-0084	A047				
5940-926-0085	A048				

SECTION v INDEX-FIGURE AND ITEM NUMBER CROSS REFERENCE
TO INDEX NUMBER

FIG. NO.	ITEM NO. OR REFERENCE DESIGNATION	INDEX NO.	FIG. NO.	ITEM NO. OR REFERENCE DESIGNATION	INDEX NO.		
5-1	B1	A008					
	B2	A050					
	DS1	A014					
	DS2	A014					
	DS3	A014					
	K2	A018					
	K3	A018					
	M1	A055					
	M2	A002					
	R32	A039					
	R33	A039					
	S1	A046					
	S2	A044					
	S3	A045					
	T1	A051					
	T2	A052					
	TB2	A005					
	TB3	A006					
	5-2	CR5		A041			
		CR13		A042			
K1		A019					
K4		A019					
R30		A038					
R31	A038						
5-3	Q1	A054					
	Q2	A053					
	Q3	A053					
5-4	C2	A003					
	CR7	A041					
	CR8	A041					
	CR9	A041					
	CR10	A041					
	TH1	A037					
5-5	R11	A029					
	R12	A028					
	R19	A031					
	R20	A021					
	R21	A022					
	R22	A023					
	R23	A024					
	R24	A025					
	R25	A026					
	R26	A027					
	R27	A030					
5-6	R1	A032					
	R2	A036					
	R3	A036					
	R4	A032					
	R5	A032					
	R6	A020					
	R6a	A033					
	R51	A034					
	R52	A034					
	R53	A035					
	R54	A033					
	R55	A035					

SECTION VI INDEX-REFERENCE DESIGNATION CROSS REFERENCE
TO INDEX NUMBER

REFERENCE DESIGNATION	INDEX NO.	REFERENCE DESIGNATION	INDEX NO.	REFERENCE DESIGNATION	INDEX NO.
E1	A008	R23	A024		
E2	A050	R24	A025		
C2	A003	R25	A026		
CR5	A041	R26	A027		
CR7	A041	R27	A030		
CR8	A041	R30	A038		
CR9	A041	R31	A038		
CR10	A041	R32	A039		
CR13	A042	R33	A039		
DS1	A014	R51	A034		
DS2	A014	R52	A034		
DS3	A014	R53	A035		
F1	A009	R54	A033		
J2	A007	R55	A035		
K1	A019	S1	A046		
K2	A018	S2	A044		
K3	A018	S3	A045		
K4	A019	T1	A051		
M1	A055	T2	A052		
M2	A002	TB2	A005		
Q1	A054	TB3	A006		
Q2	A053	TH1	A037		
Q3	A053	XF1	A010		
R1	A032				
R2	A036				
R3	A036				
R4	A032				
R5	A032				
R6	A020				
R6a	A033				
R11	A029				
R12	A028				
R19	A031				
R20	A021				
R21	A022				
R22	A023				

6-4. Discharge, Main Charge, and Topping Charge Test

a. Test Equipment and Material.

Battery, Storage BB-433/A (known good and fully charged).

Multimeter ME-87/U.

Transformer, Variable Power TF-171/USM.

Multimeter TS-352B/U.

b. Test Connections and Conditions. Connect the equipment as shown in figure 6-1 except for the ME-87/U and BB-433/A. Connect the ME-87/U and BB-433A/U when instructed to do so (*c* below).

c. Procedure.

Caution: Set the AC POWER ON-OFF switch to OFF when SELECTOR switch is to be set from one position to another. After SELECTOR switch is set to the desired position, set the AC POWER ON-OFF switch to ON.

Control settings				
Step No.	Test equipment	Equipment under test	Test procedure	Performance standard
1.	TF-171/USM: DIAL: 117 TS-352B/U FUNCTION: AC VOLTS	AC POWER ON-OFF: OFF TIMER: (S) DISCHARGE SELECTOR: MA-5 AUTOMATIC CYCLE-MAN- UAL DISCHARGE: AUTOMATIC CYCLE	<p>a. Connect TF-171/USM to ac line cord of AN/ASM-137. Using TS-352B/U, adjust dial on TF-171/USM for an output of 117 volts ac.</p> <p>b. Connect a test lead from the 150-volt terminal on the ME-87/U to the negative terminal of VOLTS meter M1 on the AN/ASM-137.</p> <p>c. Connect a test lead from the AMPS/VOLTS + terminal on the ME-87/U to the positive terminal of VOLTS meter M1 on the AN/ASM-137.</p> <p>d. Connect the fully charged known good BB-433A/U to the AN/ASM-137 and set the AC POWER ON-OFF switch to ON.</p> <p>e. Observe the indication on VOLTS meter M1.</p> <p>f. While depressing the PRESS FOR VOLTAGE switch on the ME-87/U, observe the voltage indication on the ME-87/U.</p> <p>g. Set the AC POWER ON-OFF switch to OFF and disconnect the BB-433A/U and ME-87/U from the AN/ASM-137. Disconnect leads of AMPERES meter M2 coming from pin E of BATTERY CABLE connector J2, and from positive terminal of VOLTS meter M1 (leads 063 and 064 on wiring diagram, fig. 8-4). Connect a test lead from the AMPS/VOLTS + terminal of the ME-87/U to terminal 2 of AMPERES meter M2 on the AN/ASM-137. Connect a test lead from the 30 AMPS terminal of the ME-87/U to the disconnected leads (use an alligator clip to keep the disconnected leads together).</p> <p>h. Connect the fully charged known good BB-433A/U to the AN/ASM-137, set the AC POWER ON-OFF switch to ON, and observe the indication on AMPERES meter M2.</p> <p>i. Observe the current indication on the ME-87/U.</p> <p>j. Set the SELECTOR switch to MA-4 and observe the indication on AMPERES meter M2.</p> <p>k. Set the SELECTOR switch to MA-7 and observe the indication on AMPERES meter M2.</p> <p>l. Set the AC POWER ON-OFF switch to OFF and disconnect the BB-433A/U from the AN/ASM-137. Interchange the test leads on AMPS/VOLTS + and the 30 AMPS terminals. (Reversing polarity of test leads will provide charging current readings on the ME-87/U.)</p> <p>m. Set SELECTOR switch to MA-5, TIMER to (2) MAIN CHARGE, AC POWER ON-OFF switch to ON, and observe the indication on AMPERES meter M2.</p> <p>n. Observe the current indication on the ME-87/U.</p> <p>o. Set SELECTOR switch to MA-4 and observe the indication on AMPERES meter M2.</p> <p>p. Set SELECTOR switch to MA-7 and observe the indication on AMPERES meter M2.</p> <p>q. Set SELECTOR switch to MA-5, TIMER to (4) TOPPING, and observe the indication on AMPERES meter M2.</p> <p>r. Set SELECTOR switch to MA-4 and observe the indication on AMPERES meter M2.</p> <p>s. Set SELECTOR switch to MA-7 and observe the indication on AMPERES meter M2.</p> <p>t. Set AC POWER ON-OFF switch to OFF and disconnect the ME-87/U and BB-433A/U from the AN/ASM-137.</p>	<p>a. None.</p> <p>b. None.</p> <p>c. None.</p> <p>d. AC POWER indicator lamp illuminates.</p> <p>e. Reading is between 23 and 28 volts.</p> <p>f. Reading is within 5 percent of the reading obtained on VOLTS meter M1 (e above).</p> <p>g. None.</p> <p>h. Discharge current reading is between 14.5 and 19.5 amperes.</p> <p>i. Reading is within 5 percent of the reading obtained on AMPERES meter M2 (h above).</p> <p>j. Discharge current reading is between 9 and 13 amperes.</p> <p>k. Discharge current reading is between 4.5 and 6.5 amperes.</p> <p>l. None.</p> <p>m. Reading is between 14 and 16 amperes.</p> <p>n. Reading is within 5 percent of the reading obtained on AMPERES meter M2 (m above).</p> <p>o. Reading is between 10 and 12 amperes.</p> <p>p. Reading is between 5 and 6 amperes.</p> <p>q. Reading is between 7.5 and 9.5 amperes.</p> <p>r. Reading is between 4 and 5 amperes.</p> <p>s. Reading is between 2 and 3 amperes.</p> <p>t. None.</p>
2	TF-171/USM DIAL: 117 TS-352B/U FUNCTION: AC VOLTS	AC POWER ON-OFF: OFF TIMER: (S) DISCHARGE SELECTOR: MA-5 AUTOMATIC CYCLE-MAN- UAL DISCHARGE: AUTOMATIC CYCLE	<p>a. Connect partially discharged BB-433A to the AN/ASM-137, set AC POWER ON-OFF switch to ON, and allow the BB-433A to discharge until BATTERY LOW lamp illuminates.</p> <p>b. Set AUTOMATIC CYCLE-MANUAL DISCHARGE switch to MANUAL DISCHARGE, and allow the BB-433A to discharge to less than 10 volts.</p> <p>c. Set AUTOMATIC CYCLE-MANUAL DISCHARGE switch to AUTOMATIC cycle, TIMER to (2) MAIN CHARGE, and observe that TIMER starts advancing when the BB-433A reaches between 18 and 20 volts.</p> <p>d. Set TIMER to (6) OFF.</p> <p>e. Turn off and disconnect equipment.</p>	<p>a. BATTERY LOW lamp illuminates when voltage of the BB-433A is between 18 and 20 volts, and AMPERES meter M2 indicates 0 ampere.</p> <p>b. AMPERES meter M2 indicates the BB-433A is discharging, and VOLTS meter M1 indicates less than 10 volts.</p> <p>c. AMPERES meter M2 indicates the BB-433A is charging, TIMER starts advancing when VOLTS meter M1 indicates between 18 and 20 volts, and BATTERY LOW lamp is extinguished.</p> <p>d. AMPERES meter M2 indicates 0 ampere.</p> <p>e. None.</p>

COLOR CODE MARKING FOR MILITARY STANDARD CAPACITORS

GROUP I Capacitors, Fixed, Various-Dielectrics, Styles CM, CN, CY, and CB

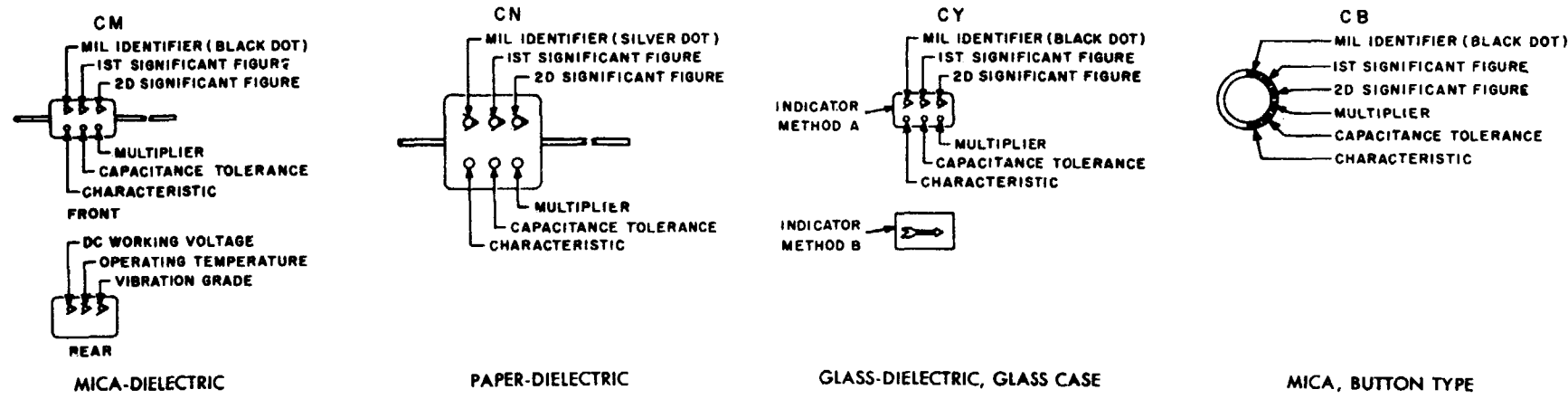

GROUP II Capacitors, Fixed Ceramic-Dielectric (General Purpose) Style CK

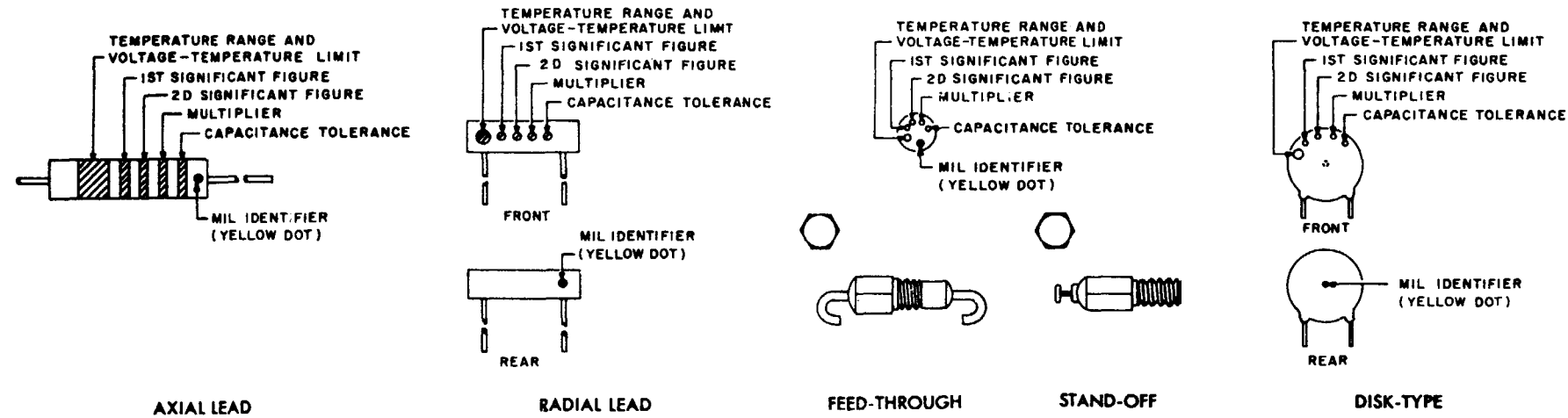

GROUP III Capacitors, Fixed, Ceramic-Dielectric (Temperature Compensating) Style CC

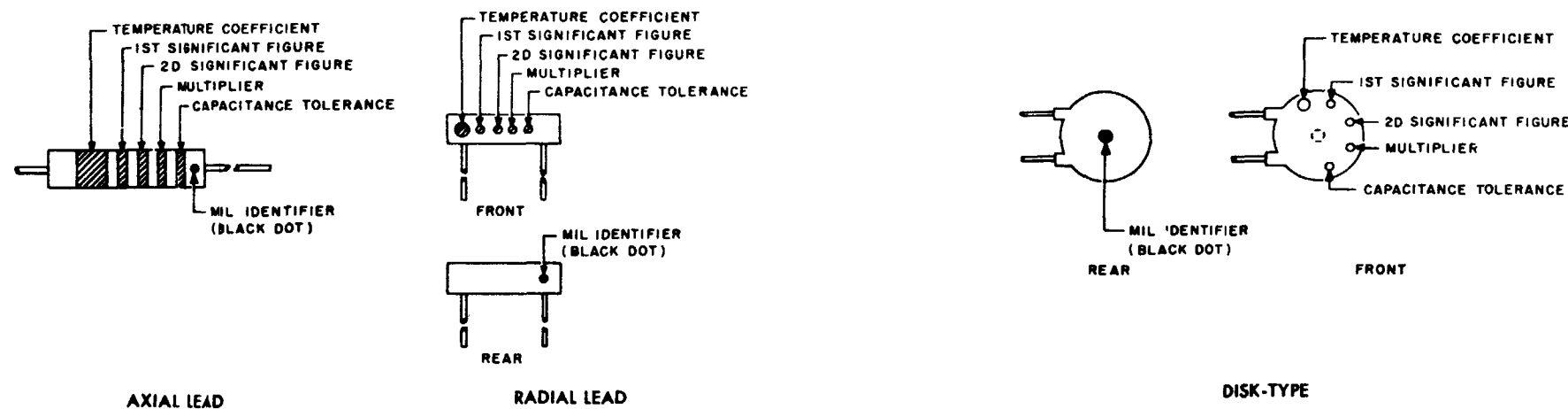

COLOR CODE TABLES

TABLE I - For use with Group I, Styles CM, CN, CY and CB

COLOR	MIL ID	1st SIG FIG	2nd SIG FIG	MULTIPLIER ¹	CAPACITANCE TOLERANCE				CHARACTERISTIC ²				DC WORKING VOLTAGE		OPERATING TEMP. RANGE		VIBRATION GRADE
					CM	CN	CY	CB	CM	CN	CY	CB	CM	CM	CM	CM	
BLACK	CM, CY, CB	0	0	1			± 20%	± 20%		A					-55° to +70°C		10-55 cps
BROWN		1	1	10					B	E		B					
RED		2	2	100	± 2%		± 2%	± 2%	C		C				-56° to +85°C		
ORANGE		3	3	1,000		± 30%			D			D	300				
YELLOW		4	4	10,000					E						-55° to +125°C		10-2,000 cps
GREEN		5	5		± 5%				F				500				
BLUE		6	6												-55° to +150°C		
PURPLE (VIOLET)		7	7														
GREY		8	8														
WHITE		9	9														
GOLD				0.1			± 5%	± 5%									
SILVER	CN				± 10%	± 10%	± 10%	± 10%									

TABLE II - For use with Group II, General Purpose, Style CK

COLOR	TEMP. RANGE AND VOLTAGE - TEMP. LIMITS ³	1st SIG FIG	2nd SIG FIG	MULTIPLIER ¹	CAPACITANCE TOLERANCE	MIL ID
BLACK		0	0	1	± 20%	
BROWN	AW	1	1	10	± 10%	
RED	AX	2	2	100		
ORANGE	BX	3	3	1,000		
YELLOW	AV	4	4	10,000		CK
GREEN	CZ	5	5			
BLUE	BY	6	6			
PURPLE (VIOLET)		7	7			
GREY		8	8			
WHITE		9	9			
GOLD						
SILVER						

TABLE III - For use with Group III, Temperature Compensating, Style CC

COLOR	TEMPERATURE COEFFICIENT ⁴	1st SIG FIG	2nd SIG FIG	MULTIPLIER ¹	CAPACITANCE TOLERANCE		MIL ID
					Capacitances over 10uuf	Capacitances 10uuf or less	
BLACK	0	0	0	1		± 2.0uuf	CC
BROWN	-30	1	1	10	± 1%		
RED	-80	2	2	100	± 2%	± 0.25uuf	
ORANGE	-150	3	3	1,000			
YELLOW	-220	4	4				
GREEN	-330	5	5		± 5%	± 0.5uuf	
BLUE	-470	6	6				
PURPLE (VIOLET)	-750	7	7				
GREY		8	8	0.01			
WHITE		9	9	0.1	± 10%		
GOLD	+100					± 1.0uuf	
SILVER							

- The multiplier is the number by which the two significant (SIG) figures are multiplied to obtain the capacitance in uuf.
- Letters indicate the Characteristics designated in applicable specifications: MIL-C-5, MIL-C-91, MIL-C-11272, and MIL-C-10950 respectively.
- Letters indicate the temperature range and voltage-temperature limits designated in MIL-C-11015.
- Temperature coefficient in parts per million per degree centigrade.

Figure 8-2. MIL-STD capacitor color code markings.

NOTE:
UNLESS OTHERWISE INDICATED,
RESISTANCES ARE IN OHMS,
CAPACITANCES ARE IN MICROFARADS.

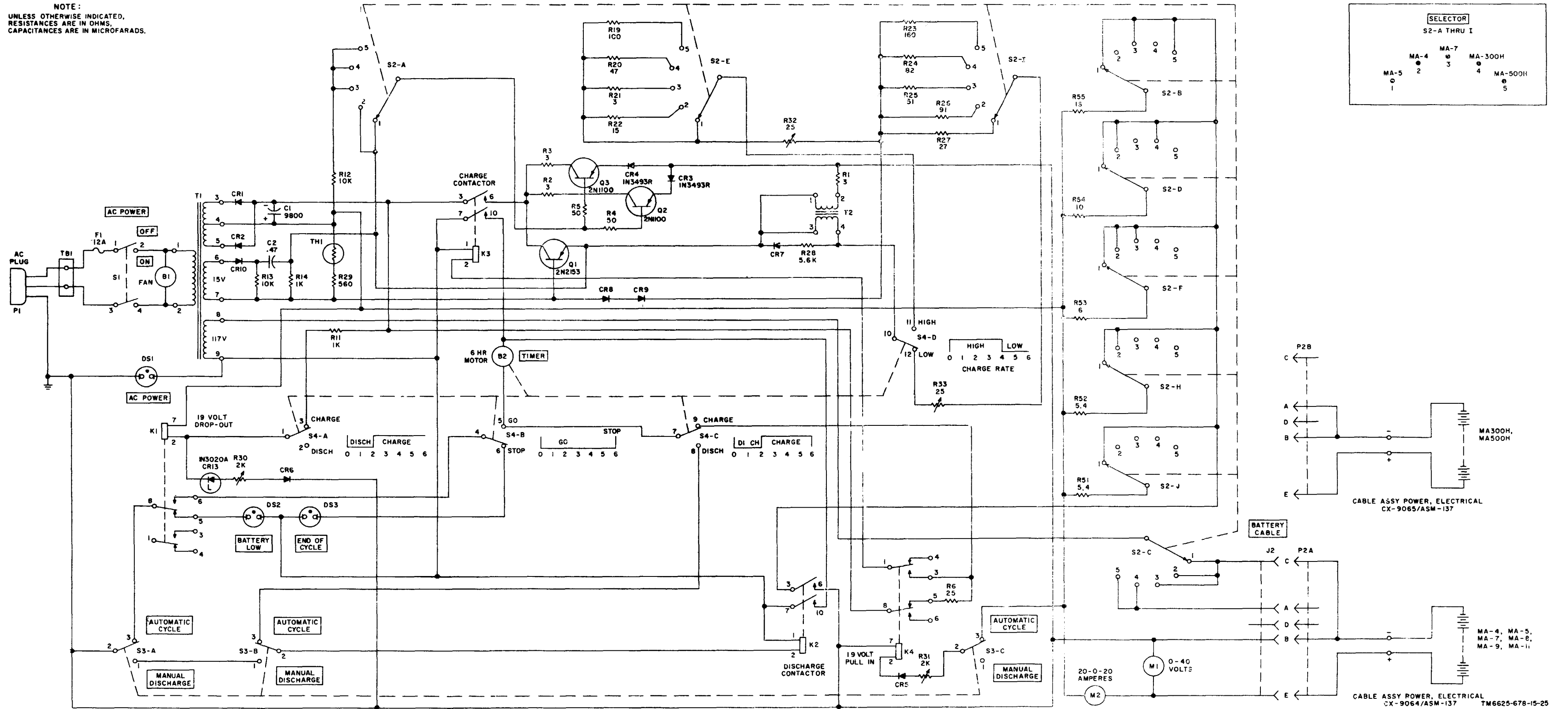

Figure 8-3. Analyzer-Charger, Battery AN/ASM-137, schematic diagram.

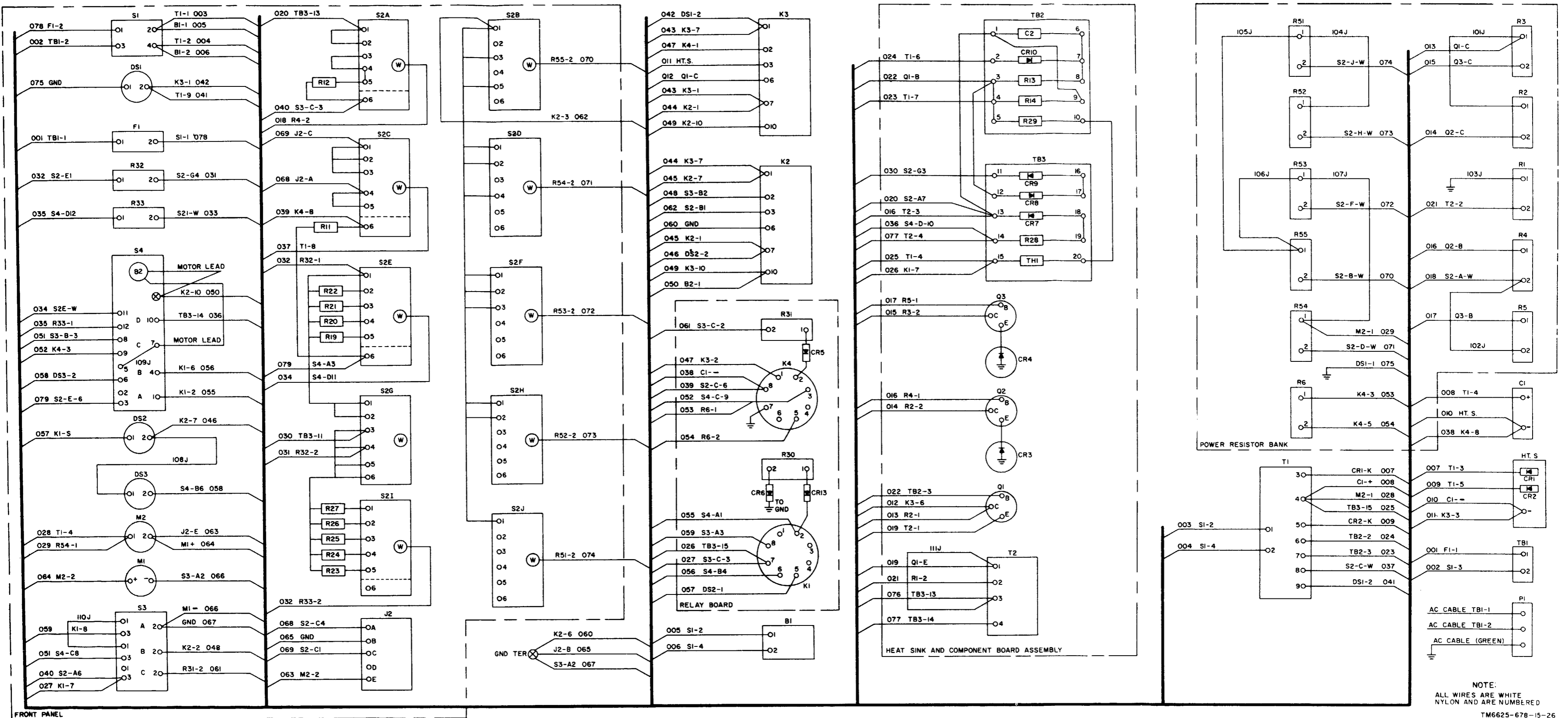

Figure 8-4. Analyzer-Charger, Battery AN/ASM-137, wiring diagram.

NOTE:
ALL WIRES ARE WHITE
NYLON AND ARE NUMBERED

By Order of the Secretary of the Army:

HAROLD K. JOHNSON,
General, United States Army,
Chief of staff.

Official:

KENNETH G. WICKHAM,
Major General, United States Army,
The Adjutant General.

Distribution:

To be distributed in accordance with DA Form 12-36 (Unclassified) requirements for Organizational Maintenance for the CH-21B, CH-21C, CH-47A O-1E, OH-13S, OV-1A, OV-1B, OV-1C, TO-1D, U-1A, U-6A, U-8F, U-10A, UH-1A, UH-1B, and UH-1D.

RECOMMENDED CHANGES TO EQUIPMENT TECHNICAL PUBLICATIONS



THEN...JOT DOWN THE DOPE ABOUT IT ON THIS FORM. CAREFULLY TEAR IT OUT, FOLD IT AND DROP IT IN THE MAIL.

SOMETHING WRONG WITH PUBLICATION

FROM: (PRINT YOUR UNIT'S COMPLETE ADDRESS)

DATE SENT

PUBLICATION NUMBER

PUBLICATION DATE

PUBLICATION TITLE

BE EXACT PIN-POINT WHERE IT IS

PAGE NO.

PARA-GRAPH

FIGURE NO.

TABLE NO.

IN THIS SPACE, TELL WHAT IS WRONG AND WHAT SHOULD BE DONE ABOUT IT.

TEAR ALONG PERFORATED LINE

PRINTED NAME, GRADE OR TITLE AND TELEPHONE NUMBER

SIGN HERE

